

Course Code: MAGC06  
 Complex Analysis, 7.5 ECTS Credits  
 (Komplex analys, 7.5 Swedish credit points)  
 Degree Level: Bachelor  
 Language of Instruction  
 Swedish or English

**Prerequisites**

Mathematics, 60 ECTS cr, including Linear Algebra, 7.5 ECTS cr, Multidimensional Calculus, 7.5 ECTS cr, and Advanced Calculus, 7.5 ECTS cr, or equivalent.

**Major Field of Study**

MAA (Mathematics)

The field of complex numbers

- absolute value, argument and De Moivre formula, the algebraic n-th root of a complex number

Exercises: p7-1.1: 2, 18, 20, 27, 28, 29, 30, 31, 32, 50

Exercises: p14-1.2: 9, 12, 13, 18, 20, 26, 28, 36, 50

Exercises: p21-1.3: 1, 2, 3, 5, 35, 37, 38

Exercises: p26-1.4: 2, 6, 13, 21, 24

# ≡ Complex Numbers ≡

$$\mathbb{C} = \mathbb{R}^2$$

$$z = x + iy$$

$$(x, y) = x(1, 0) + y(0, 1)$$

$$= x + yi$$



Figure 1.2 z as a position vector

Some equations have solutions in  $\mathbb{R}$

$$2x + 1 = 7 \Leftrightarrow x = 3$$

But  $x^2 = -1$  has no solution in  $\mathbb{R}$ .

We introduce a new number "Imaginary unit"  $i$

So  $i^2 = -1$

$$(x, y) = (u, v) \Leftrightarrow \begin{cases} x = u \\ y = v \end{cases}$$

$$(x, y) + (u, v) = (x+u, y+v)$$

$$(a + bi)(c + id) = ac + axd + xbc + \underbrace{x^2}_{-1}bd = (ac - bd) + i(ad + bc)$$

$$(x, y)(u, v) = (xu - yv, xv + yu)$$

$$(x, y) + (0, 0) = (x, y)$$

$$(x, y)(1, 0) = (x \cdot 1 - y \cdot 0, x \cdot 0 + y \cdot 1)$$

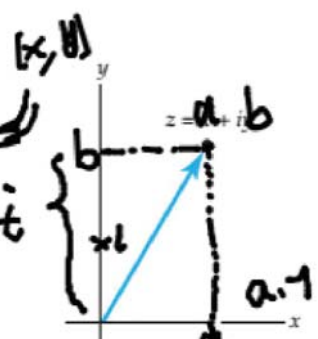

Let  $z = a + ib \in \mathbb{C}$ ,  $a = \text{Re } z$   
 $b = \text{Im } z$

We identify  $a \in \mathbb{R}$  with the point  $(a, 0) \Rightarrow \mathbb{R} \subset \mathbb{C}$

Figure 1.3 z as a position vector

**Arithmetic Operations** Complex numbers can be added, subtracted, multiplied, and divided. If  $z_1 = a_1 + ib_1$  and  $z_2 = a_2 + ib_2$ , these operations are defined as follows.

**Addition:**  $z_1 + z_2 = (a_1 + ib_1) + (a_2 + ib_2) = (a_1 + a_2) + i(b_1 + b_2)$

**Subtraction:**  $z_1 - z_2 = (a_1 + ib_1) - (a_2 + ib_2) = (a_1 - a_2) + i(b_1 - b_2)$

**Multiplication:**  $z_1 \cdot z_2 = (a_1 + ib_1)(a_2 + ib_2)$   
 $= a_1a_2 - b_1b_2 + i(b_1a_2 + a_1b_2)$

**Division:**  $\frac{z_1}{z_2} = \frac{a_1 + ib_1}{a_2 + ib_2}, a_2 \neq 0, \text{ or } b_2 \neq 0$   
 $= \frac{a_1a_2 + b_1b_2}{a_2^2 + b_2^2} + i \frac{b_1a_2 - a_1b_2}{a_2^2 + b_2^2}$

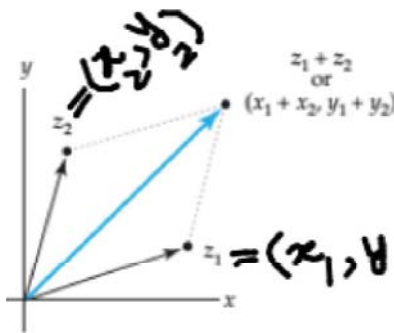

(a) Vector sum

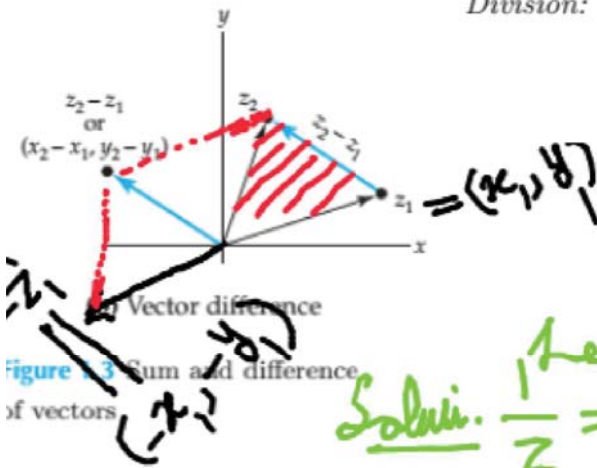

Figure 1.3 Sum and difference of vectors

Exercise:  $\frac{1}{z}$ ?

Soln.  $\frac{1}{z} = w$ . Then  $zw = 1 = (ax - by) + i(ay + bx)$   
 $a+ib \quad x+iy$

$$\begin{cases} ax - by = 1 \\ ay + bx = 0 \end{cases} \Rightarrow \begin{cases} x = \frac{a}{a^2 + b^2} \\ y = \frac{-b}{a^2 + b^2} \end{cases} \textcircled{1}$$

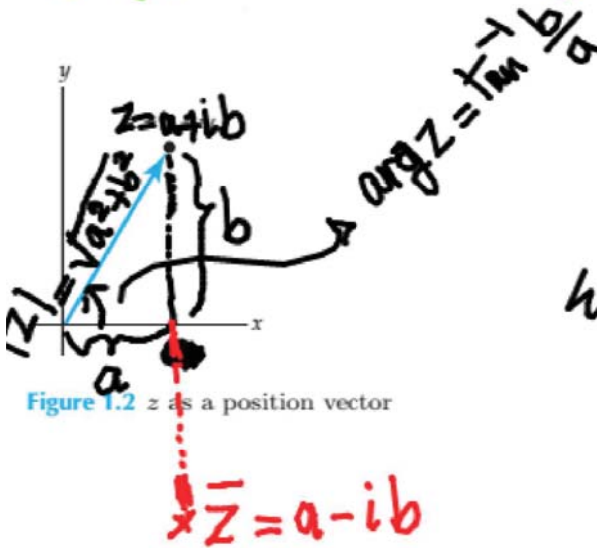

Figure 1.2  $z$  as a position vector

$z \bar{z} = (a+ib)(a-ib) = a^2 + b^2 = |z|^2$   
 $a+ib = |z|$   
 $a = |z| \cos \theta$   
 $b = |z| \sin \theta$

What is  $\frac{1}{z}$ ?

$\frac{1}{z} = \frac{1 \cdot \bar{z}}{z \cdot \bar{z}} = \frac{\bar{z}}{|z|^2} = \frac{a-ib}{a^2+b^2}$   
 $= \frac{a}{a^2+b^2} + i \frac{-b}{a^2+b^2} \textcircled{2}$

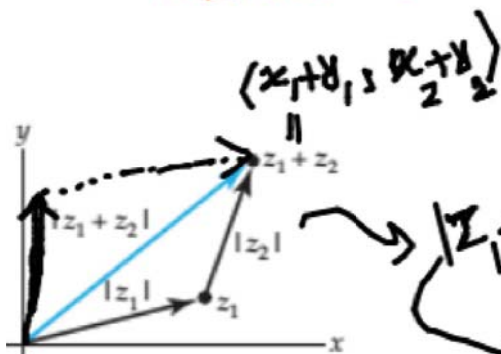

Figure 1.5 Triangle with vector sides

$|z_1 + z_2| \leq |z_1| + |z_2|$   
 $\sqrt{(x_1+y_1)^2 + (x_2-y_1)^2} \leq \sqrt{x_1^2+y_1^2} + \sqrt{x_2^2+y_2^2}$

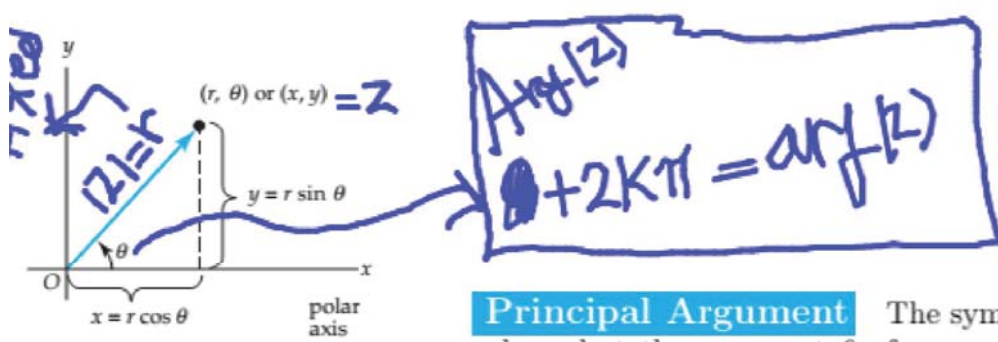

Figure 1.7 Polar coordinates in the complex plane

Be careful using  $\tan^{-1}(y/x)$

$$r = \sqrt{x^2 + y^2}$$

$$\theta = \tan^{-1} \frac{y}{x}$$

My room  
21F 512

My email: [moslehian@yahoo.com](mailto:moslehian@yahoo.com)  
 Google+: [moslehian](#)

**Principal Argument** The symbol  $\arg(z)$  actually represents a set of values, but the argument  $\theta$  of a complex number that lies in the interval  $-\pi < \theta \leq \pi$  is called the **principal value** of  $\arg(z)$  or the **principal argument** of  $z$ . The principal argument of  $z$  is *unique* and is represented by the symbol  $\text{Arg}(z)$ , that is,

$$-\pi < \text{Arg}(z) \leq \pi.$$

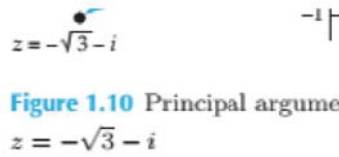

Figure 1.10 Principal argument  
 $z = -\sqrt{3} - i$

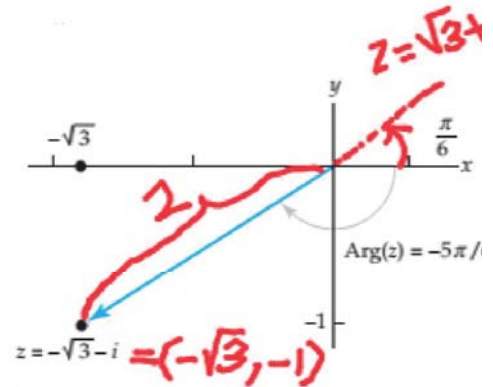

Figure 1.10 Principal argument  
 $z = \sqrt{3} - i$

$$z = x + iy = r \cos \theta + ir \sin \theta$$

$$= r (\cos \theta + i \sin \theta)$$

$$= r \text{cis } \theta$$

$$z_1 z_2 = r_1 \text{cis } \theta_1 \cdot r_2 \text{cis } \theta_2$$

$$= (r_1 \cos \theta_1 + i r_1 \sin \theta_1) (r_2 \cos \theta_2 + i r_2 \sin \theta_2)$$

$$= (r_1 r_2 \cos \theta_1 \cos \theta_2 - r_1 r_2 \sin \theta_1 \sin \theta_2) + i (\dots)$$

$$= r_1 r_2 \cos (\theta_1 + \theta_2) + i r_1 r_2 \sin (\theta_1 + \theta_2)$$

$$= r_1 r_2 \text{cis } (\theta_1 + \theta_2)$$

$$z^2 = r^2 \text{cis } (2\theta), \dots, z^n = r^n \text{cis } (n\theta) \text{ when } z = r \text{cis } \theta$$

$$r = \sqrt{3 + 1} = 2$$

$$\theta = \tan^{-1} \frac{-1}{\sqrt{3}} = \tan^{-1} \frac{\sqrt{3}}{3} = \frac{\pi}{6}, \pi + \frac{\pi}{6}$$

$-\pi < \theta \leq \pi$

$-\frac{5\pi}{6} < \theta < -\frac{\pi}{6}$

$k\pi + \frac{\pi}{6}$

# de Moivre's Formula

and so (9) yields

$$(\cos \theta + i \sin \theta)^n = \cos n\theta + i \sin n\theta. \quad (10)$$

This last result is known as de Moivre's formula and is useful in deriving certain trigonometric identities involving  $\cos n\theta$  and  $\sin n\theta$ . See Problems 33 and 34 in Exercises 1.3.

## EXAMPLE 4 de Moivre's Formula

From (10), with  $\theta = \pi/6$ ,  $\cos \theta = \sqrt{3}/2$  and  $\sin \theta = 1/2$ :

$$\begin{aligned} \left(\frac{\sqrt{3}}{2} + \frac{1}{2}i\right)^3 &= (\cos \frac{\pi}{6} + i \sin \frac{\pi}{6})^3 \\ &= \cos \left(3 \cdot \frac{\pi}{6}\right) + i \sin \left(3 \cdot \frac{\pi}{6}\right) \\ &= \cos \frac{\pi}{2} + i \sin \frac{\pi}{2} = i. \end{aligned}$$

$$r = \sqrt{\left(\frac{\sqrt{3}}{2}\right)^2 + \left(\frac{1}{2}\right)^2} = 1, \quad \theta = \tan^{-1} \frac{1}{\sqrt{3}} = \frac{\pi}{6}$$

What is  $(z)^{1/n}$ ?

Let  $z = a + ib = r \operatorname{cis} \theta$  we want to find  $w = x + iy = t \operatorname{cis} \phi$  such that  $w^n = z$ . So  $(t \operatorname{cis} \phi)^n = r \operatorname{cis} \theta$

$$\begin{aligned} \underbrace{t^n \operatorname{cis}(n\phi)}_{t^n \cos(n\phi) + i t^n \sin(n\phi)} &= \underbrace{r \operatorname{cis} \theta}_{r \cos \theta + i r \sin \theta} \end{aligned}$$

tence  $\begin{cases} t^n \cos(n\phi) = r \cos \theta \\ t^n \sin(n\phi) = r \sin \theta \end{cases} \Rightarrow t^{2n} (\cos^2(n\phi) + \sin^2(n\phi)) = r^2 (\cos^2 \theta + \sin^2 \theta)$

$$r^2 (\cos^2 \theta + \sin^2 \theta) \Rightarrow t = \sqrt[n]{r}$$

$$w = \sqrt[n]{r} \operatorname{cis} \frac{2k\pi + \theta}{n}$$

$$\phi = \frac{2k\pi + \theta}{n}$$

$$n\phi = 2k\pi + \theta$$

Let  $z = 1 = 1 \operatorname{cis} 0$   
 $r = 1, \theta = 0$   
 $z^{1/n} = \sqrt[n]{1} \operatorname{cis} \frac{2k\pi}{n}$   
 $= \operatorname{cis} \frac{2k\pi}{n} \quad k=1, 2, \dots$

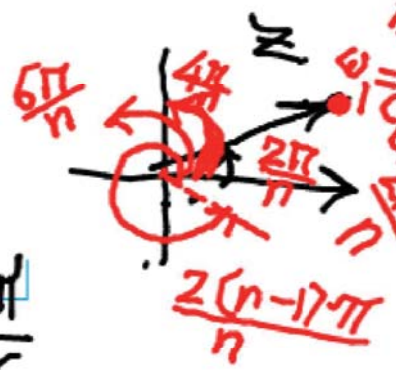



$$N_r(z_0) = \{z \in \mathbb{C} \mid |z - z_0| < r\}$$

$$N'_r(z_0) = N_r(z_0) - \{z_0\}$$

$$\mathbb{C} = \mathbb{R}^2$$

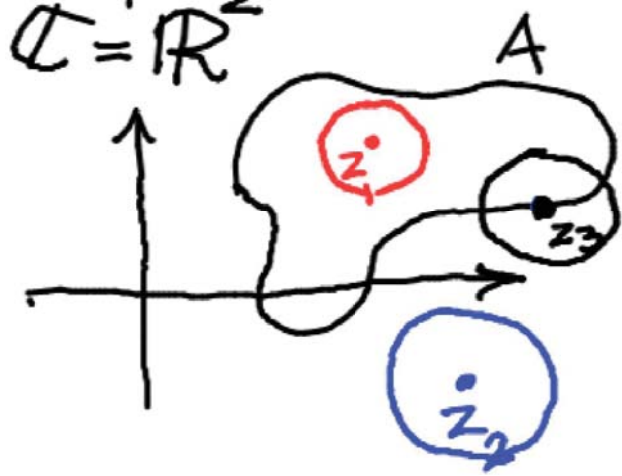

$z_1 \in A^\circ$  if  $\exists N_r(z_1) \subseteq A$   
 $\rightarrow$  interior point

$z_2 \in \text{Ext}(A)$  if  $\exists N_r(z_2) \cap A = \emptyset$

$z_3 \in \partial A$  if  $\forall s, N_s(z_3) \cap A \neq \emptyset$

We say  $\Sigma$  " " " " closed "  $\partial A \subseteq A$

$$N_s(z_3) \cap A^c \neq \emptyset$$



Connected.

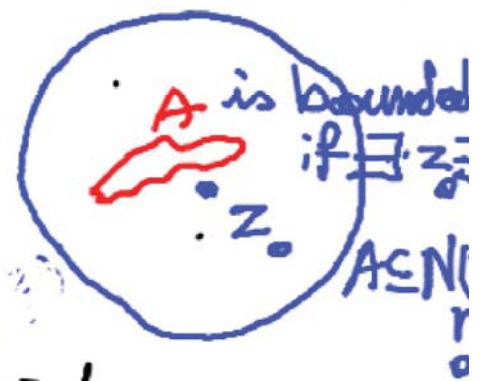

Domain = a connected open set  
 Region = a set (containing a domain)

### Types of functions.

$f: X \rightarrow \mathbb{R} \subset \mathbb{R}^n$   
 real-valued function  
 complex  $\Leftarrow$   
 vector  $\Leftarrow$

$f: \mathbb{C} \rightarrow \mathbb{C}$   
 a complex function

$$w = f(z)$$

$$u+iv = f(x+iy)$$

$$u: \mathbb{R}^2 \rightarrow \mathbb{R} \leftarrow u(x,y) \quad v: \mathbb{R}^2 \rightarrow \mathbb{R} \leftarrow v(x,y)$$

$$e^{i\theta} := \text{cis } \theta$$

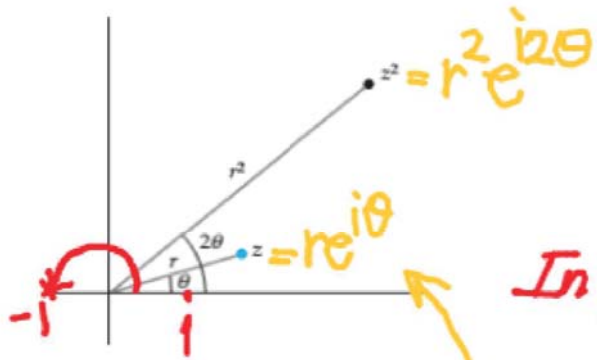

Figure 2.17 The mapping  $w = z^2$

$\text{Arg}(z_1 \cdot z_2) \neq \text{Arg } z_1 + \text{Arg } z_2$   
 In particular:

$$\text{Arg}(z^2) \neq 2 \text{Arg } z$$

For example take  $z = -1$ . Then

$$\text{Arg}(z) = \text{Arg}(-1) = (\pi), \quad \text{Arg}(z^2) = \text{Arg}(1) = 0$$

$$f(z) = z^2 = (x+iy)(x+iy) = \underbrace{x^2 - y^2}_{u(x,y)} + \underbrace{2xy}_{v(x,y)} i$$

$$f(z) = f(r \text{cis } \theta) = (r \text{cis } \theta)^2 = r^2 \text{cis}(2\theta) = \underbrace{r^2 \cos(2\theta)}_{u(r,\theta)} + \underbrace{r^2 \sin(2\theta)}_{v(r,\theta)} i$$

Recall that the graph of function  $f: X \rightarrow Y$ :

$$\text{Gr}(f) = \{(x, f(x)) \mid x \in \text{Dom}(f)\} \subseteq X \times Y$$

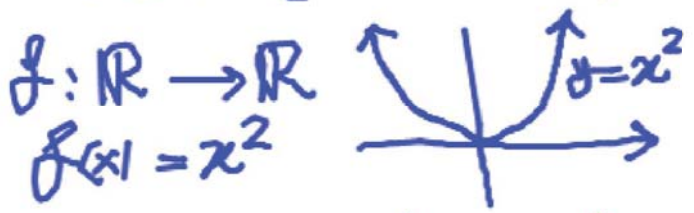

We cannot draw the graph of a complex function

$$f: \underbrace{\mathbb{C}}_{\mathbb{R}^2} \rightarrow \underbrace{\mathbb{C}}_{\mathbb{R}^2} : \text{Gr}(f) \subseteq \mathbb{R}^4 \quad S' = f(S) = \{f(z) \mid z \in S\}$$

But we can find the image of a set  $S$  under a complex function  $f$ . (see next slide)

We have some specific functions:



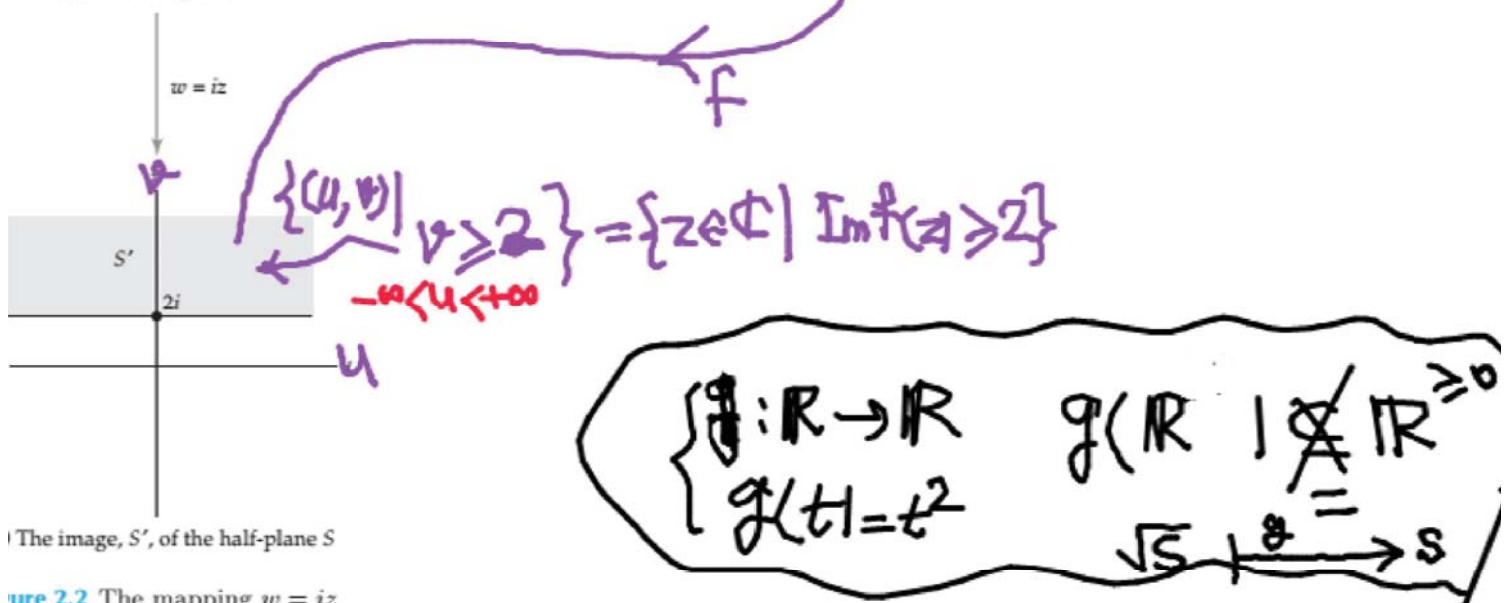
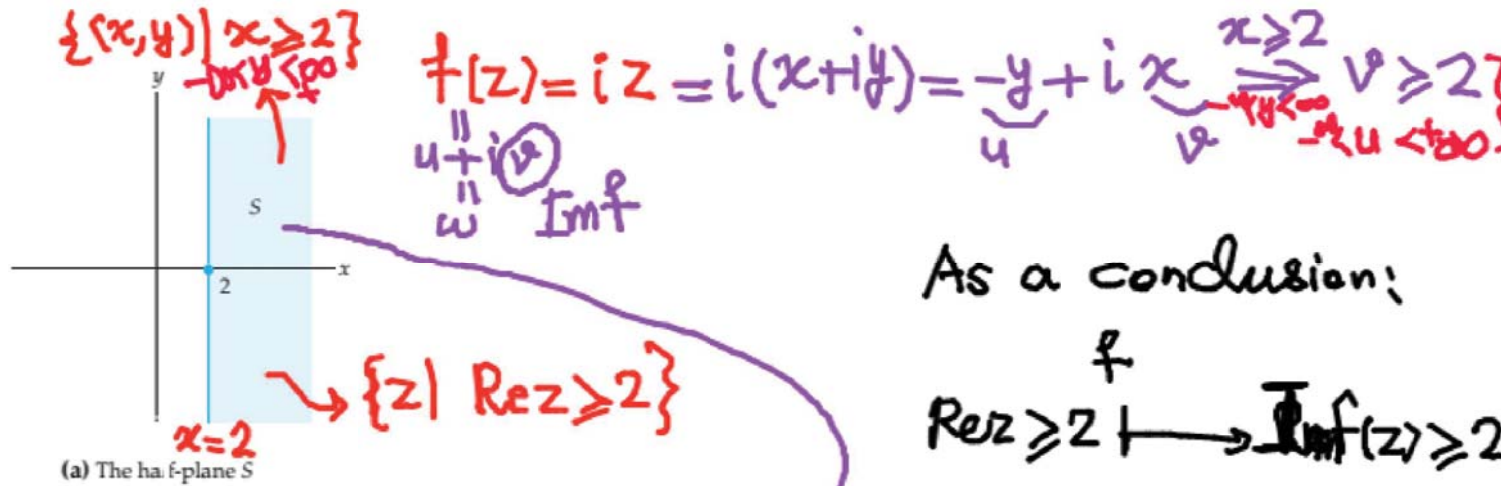

Two important complex functions:

1) Exp:  $e^z = e^x \text{cis } y \xrightarrow{z=0} e^{iy} = \text{cis } y$

2) log:  $\log z = \log(re^{i\theta}) = \log r + \log e^{i\theta} = \log r + i\theta = \log|z| + i \arg z$

a multi-valued function

To have a usual  $\text{Log}$  function we should restrict  $\arg z$  to a given interval:  
 $\theta_0 < \arg z \leq \theta_0 + 2\pi$

If we take  $\theta_0 = -\pi$ , then we get the main branch of  $\log$ , denoted by  $\text{Log}$ :  
 $\text{Log}: \mathbb{C} \rightarrow \mathbb{C}$   
 $z = re^{i\theta} \mapsto \log r + i\theta, -\pi < \theta \leq \pi$

### Definition 2.3 Parametric Curves in the Complex Plane

If  $x(t)$  and  $y(t)$  are real-valued functions of a real variable  $t$ , then the set  $C$  consisting of all points  $z(t) = x(t) + iy(t)$ ,  $a \leq t \leq b$ , is called a **parametric curve** or a **complex parametric curve**. The complex-valued function of the real variable  $t$ ,  $z(t) = x(t) + iy(t)$ , is called a **parametrization** of  $C$ .

by a curve we mean a cts function  $z(t) : [a, b] \rightarrow \mathbb{C}$   
 $t \mapsto x(t) + iy(t)$   
 continuous

#### Line Segment

A parametrization of the line segment from  $z_0$  to  $z_1$  is:

$$z(t) = z_0(1-t) + z_1t, \quad 0 \leq t \leq 1. \quad (7)$$

#### Ray

A parametrization of the ray emanating from  $z_0$  and containing  $z_1$  is:

$$z(t) = z_0(1-t) + z_1t, \quad 0 \leq t < \infty. \quad (8)$$

#### Circle

A parametrization of the circle centered at  $z_0$  with radius  $r$  is:

$$z(t) = z_0 + r(\cos t + i \sin t), \quad 0 \leq t \leq 2\pi. \quad (9)$$

In exponential notation, this parametrization is:

$$z(t) = z_0 + re^{it}, \quad 0 \leq t \leq 2\pi. \quad (10)$$

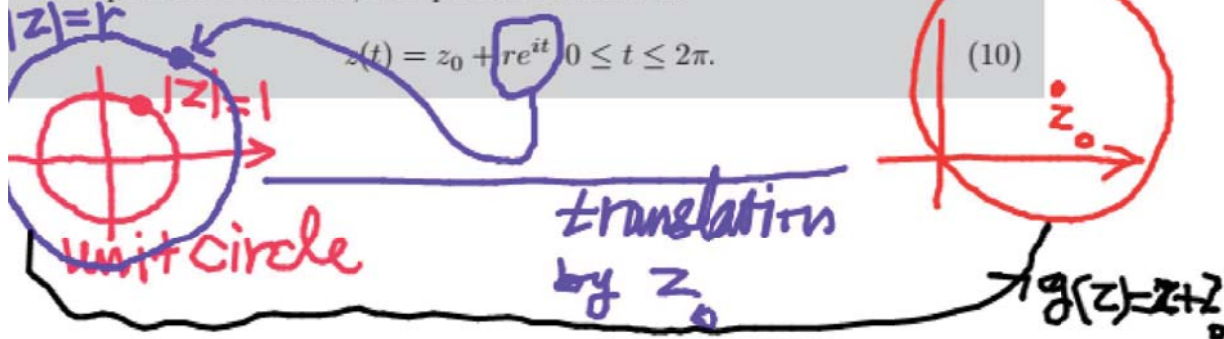

### Image of a Parametric Curve under a Complex Mapping

If  $w = f(z)$  is a complex mapping and if  $C$  is a curve parametrized by  $z(t)$ ,  $a \leq t \leq b$ , then

$$w(t) = f(z(t)), \quad a \leq t \leq b \quad (11)$$

#### EXAMPLE 4 Image of a Parametric Curve

Find the image of the semicircle shown in color in Figure 2.6 under the complex mapping  $w = z^2$ .

**Solution** Let  $C$  denote the semicircle shown in Figure 2.6 and let  $C'$  denote its image under  $f(z) = z^2$ . We proceed as in Example 3. By setting  $z_0 = 2$  and  $r = 2$  in (10) we obtain the following parametrization of  $C$ :

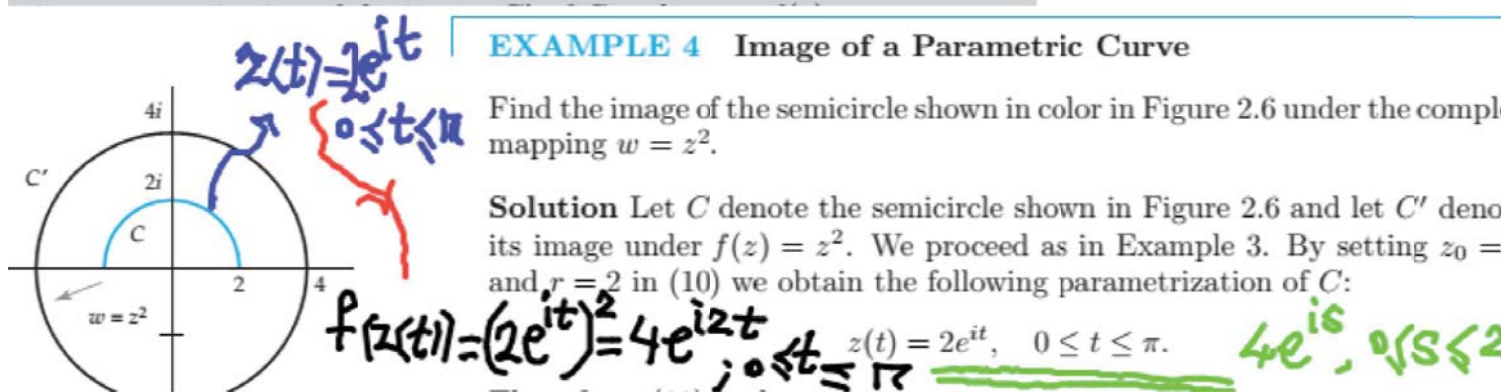



Some Exercises:

$$1) z + \bar{z} = (x+iy) + (x-iy) = 2x = 2\operatorname{Re}z$$

$$2) ||z_1 - z_2| \leq |z_1 - z_2| \leq |z_1| + |z_2|$$

$$|z_1 + (-z_2)| \leq |z_1| + |-z_2|$$

$$|z_1| = |(z_1 - z_2) + z_2| \leq |z_1 - z_2| + |z_2|$$

$$|z_1| - |z_2| \leq |z_1 - z_2| \quad \textcircled{1}$$

$$\text{similarly } |z_2| - |z_1| \leq |z_2 - z_1| = |z_1 - z_2| \quad \textcircled{2}$$

$$\textcircled{1}, \textcircled{2} \Rightarrow ||z_1| - |z_2|| \leq |z_1 - z_2|$$

$$\begin{cases} a < b \\ a > b \end{cases} \Rightarrow |a| < b$$



what is  $i^{1/4}$ ?

$$i = 1 \operatorname{cis} \frac{\pi}{2}$$

$$i^{1/4} = \sqrt[4]{1} \operatorname{cis} \frac{2k\pi + \pi/2}{4}$$

$$k=0,1,2,3 \Rightarrow \begin{cases} \operatorname{cis} \frac{\pi}{8} \\ \operatorname{cis} \frac{5\pi}{8} \\ \operatorname{cis} \frac{9\pi}{8} \\ \operatorname{cis} \frac{13\pi}{8} \end{cases}$$

$$z = re^{i\theta} \Rightarrow z^{1/n} = \sqrt[n]{r} \operatorname{cis} \frac{2k\pi + \theta}{n}$$

$$k=0,1,\dots,n-1$$

$$k=n \Rightarrow \operatorname{cis} \frac{2n\pi + \theta}{n} = \operatorname{cis} \frac{\theta}{n}$$

$$k=n+1 \Rightarrow \operatorname{cis} \frac{2(n+1)\pi + \theta}{n} = \operatorname{cis} \frac{\theta}{n}$$

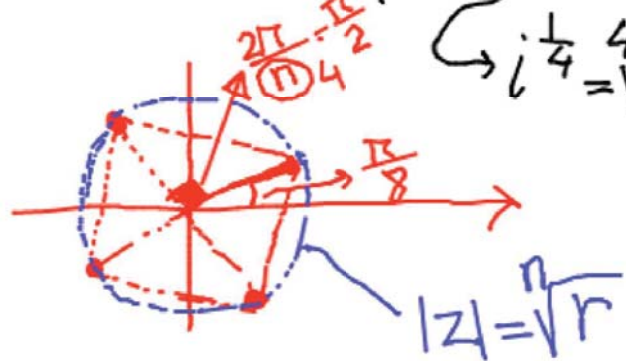

.) Prove  $|z_1 + z_2| \leq |z_1| + |z_2|$ .

Proof.

$$|z_1 + z_2|^2 = (z_1 + z_2)(\overline{z_1 + z_2}) = (z_1 + z_2)(\bar{z}_1 + \bar{z}_2)$$

$$= z_1 \bar{z}_1 + z_1 \bar{z}_2 + z_2 \bar{z}_1 + z_2 \bar{z}_2$$

$$= |z_1|^2 + 2 \operatorname{Re}(z_1 \bar{z}_2) + |z_2|^2$$

$$\leq |z_1|^2 + 2|z_1||z_2| + |z_2|^2 \quad (\text{Since } \operatorname{Re} w = a \leq \sqrt{a^2 + b^2} = |w|)$$

$$= |z_1|^2 + 2|z_1||z_2| + |z_2|^2 = (|z_1| + |z_2|)^2 \quad \square$$

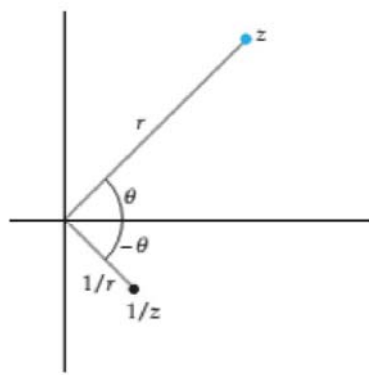

Figure 2.39 The reciprocal mapping

$$w = f(z) = \frac{1}{z}$$

$$z = re^{i\theta} \xrightarrow{f} \frac{1}{re^{i\theta}} = \frac{1}{r} e^{i(-\theta)} = w$$

$$\sum \begin{cases} w = \frac{1}{z} \\ -\pi < \theta \leq 0 \end{cases}$$

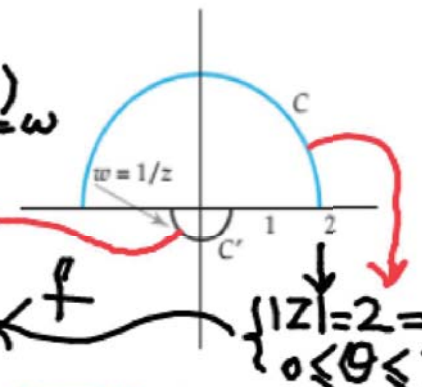

Figure 2.42 The reciprocal mapping

**EXAMPLE 2** Image of a Line under  $w = 1/z$

Find the image of the vertical line  $x = 1$  under the reciprocal mapping  $w = 1/z$ .

**Solution** The vertical line  $x = 1$  consists of the set of points  $z = 1 + iy$ ,  $-\infty < y < \infty$ . After replacing the symbol  $z$  with  $1 + iy$  in  $w = 1/z$  and simplifying, we obtain:

$$w = \frac{1}{z} = \frac{1}{1+iy} = \frac{1}{1+iy} \cdot \frac{1-iy}{1-iy} = \frac{1-iy}{1+y^2}$$

$$w = \frac{1}{1+iy} = \frac{1}{1+y^2} - \frac{y}{1+y^2}i$$

It follows that the image of the vertical line  $x = 1$  under  $w = 1/z$  consists of all points  $u + iv$  satisfying:

$$u = \frac{1}{1+y^2}, \quad v = \frac{-y}{1+y^2}, \quad \text{and} \quad -\infty < y < \infty. \quad (3)$$

We can describe this image with a single Cartesian equation by eliminating the variable  $y$ . Observe from (3) that  $v = -yu$ . The first equation in (3) implies that  $u \neq 0$ , and so can rewrite this equation as  $y = -v/u$ . Now we substitute  $y = -v/u$  into the first equation of (3) and simplify to obtain the quadratic equation  $u^2 - u + v^2 = 0$ . Therefore, after completing the square in the variable  $u$ , we see that the image given in (3) is also given by:

$$\left(u - \frac{1}{2}\right)^2 + v^2 = \frac{1}{4}, \quad u \neq 0. \quad (4)$$

The equation in (4) defines a circle centered at  $(\frac{1}{2}, 0)$  with radius  $\frac{1}{2}$ . However, because  $u \neq 0$ , the point  $(0, 0)$  is not in the image. Using the complex variable  $w = u + iv$ , we can describe this image by  $|w - \frac{1}{2}| = \frac{1}{2}, w \neq 0$ . We represent this mapping using a single copy of the complex plane. In Figure 2.43, the line  $x = 1$  shown in color is mapped onto the circle  $|w - \frac{1}{2}| = \frac{1}{2}$  excluding the point  $w = 0$  shown in black by  $w = 1/z$ .

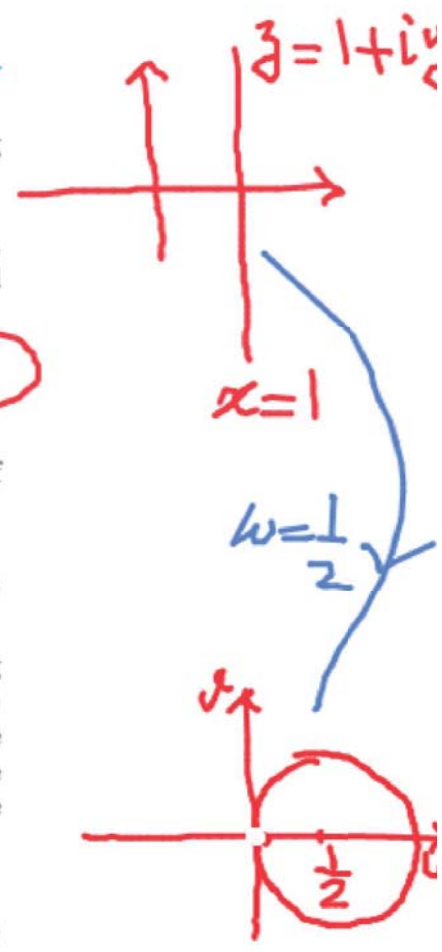

$$|\bar{z}| = |\overline{x-iy}| = \sqrt{x^2 + (-y)^2} = \sqrt{x^2 + y^2} = |z|$$

$$|\overline{z - z_0}| = |\overline{z} - \overline{z_0}| = |z - z_0| = r$$

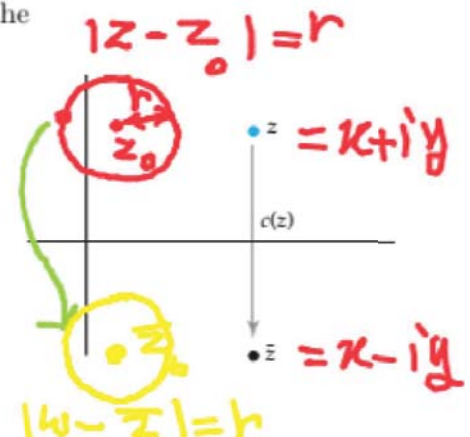

Figure 2.41 Complex conjugation

## Definition 2.8 Limit of a Complex Function

Suppose that a complex function  $f$  is defined in a deleted neighborhood of  $z_0$  and suppose that  $L$  is a complex number. The **limit of  $f$  as  $z$  tends to  $z_0$  exists and is equal to  $L$** , written as  $\lim_{z \rightarrow z_0} f(z) = L$ , if for every  $\varepsilon > 0$  there exists a  $\delta > 0$  such that  $|f(z) - L| < \varepsilon$  whenever  $0 < |z - z_0| < \delta$ .



If  $\lim_{z \rightarrow z_0} f(z) = f(z_0)$ , then we say  $f$  is cts at  $z_0$ , continuous

### EXAMPLE 1 A Limit That Does Not Exist

Show that  $\lim_{z \rightarrow 0} \frac{z}{\bar{z}}$  does not exist.

**Solution** We show that this limit does not exist by finding two different ways of letting  $z$  approach 0 that yield different values for  $\lim_{z \rightarrow 0} \frac{z}{\bar{z}}$ . First, we let  $z$  approach 0 along the real axis. That is, we consider complex numbers of the form  $z = x + 0i$  where the real number  $x$  is approaching 0. For these points we have:

$$\lim_{z \rightarrow 0} \frac{z}{\bar{z}} = \lim_{x \rightarrow 0} \frac{x + 0i}{x - 0i} = \lim_{x \rightarrow 0} 1 = 1. \quad (2)$$

On the other hand, if we let  $z$  approach 0 along the imaginary axis, then  $z = 0 + iy$  where the real number  $y$  is approaching 0. For this approach we have:

$$\lim_{z \rightarrow 0} \frac{z}{\bar{z}} = \lim_{y \rightarrow 0} \frac{0 + iy}{0 - iy} = \lim_{y \rightarrow 0} (-1) = -1. \quad (3)$$

Since the values in (2) and (3) are not the same, we conclude that  $\lim_{z \rightarrow 0} \frac{z}{\bar{z}}$  does not exist.

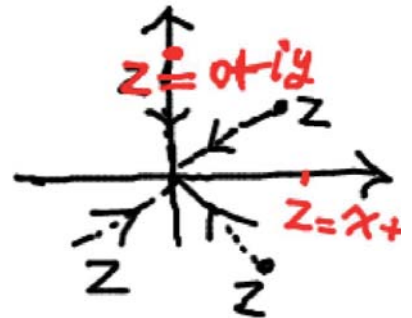

$$\begin{aligned} |z| &= |\operatorname{Re} z + i \operatorname{Im} z| \\ &\leq |\operatorname{Re} z| + |i \operatorname{Im} z| \\ &= |\operatorname{Re} z| + |\operatorname{Im} z| \end{aligned}$$

### Theorem 2.1 Real and Imaginary Parts of a Limit

Suppose that  $f(z) = u(x, y) + iv(x, y)$ ,  $z_0 = x_0 + iy_0$ , and  $L = u_0 + iv_0$ . Then  $\lim_{z \rightarrow z_0} f(z) = L$  if and only if

$$\lim_{(x,y) \rightarrow (x_0,y_0)} u(x, y) = u_0 \quad \text{and} \quad \lim_{(x,y) \rightarrow (x_0,y_0)} v(x, y) = v_0.$$

$$\begin{aligned} \Rightarrow |u(x,y) - u_0| &= |\operatorname{Re} f(z) - \operatorname{Re} L| = |\operatorname{Re}(f(z) - L)| \leq |f(z) - L| \\ \Leftarrow |f(z) - L| &= |u(x,y) - u_0 + i(v(x,y) - v_0)| \leq |u(x,y) - u_0| + |v(x,y) - v_0| \end{aligned}$$

$$\begin{aligned} a+ib \\ |\operatorname{Re} z| &= |a| \leq \sqrt{a^2 + b^2} \\ &= |z| \end{aligned}$$

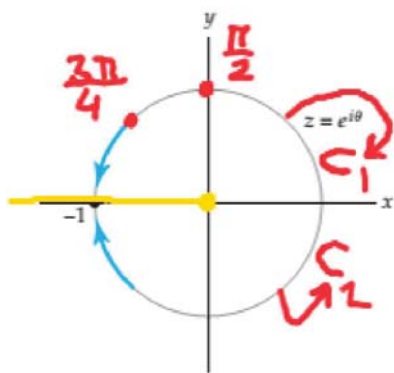

Figure 2.54 Figure for Example 6

Consider  $\text{Log } z = \log r + i\theta$ ,  $z \neq 0$ ,  $-\pi < \theta \leq \pi$

$f(z) \rightarrow \text{cts}$

$\ln r \rightarrow u(r, \theta)$

$i\theta \rightarrow v(r, \theta)$

$\lim_{z \rightarrow -1} \theta = \pi$  &  $\lim_{z \rightarrow -1} \theta = -\pi$

$C_1 \neq C_2$

$\Rightarrow v(r, \theta)$  is not cts at  $z = -1$

Note that  $e^z = e^x \cos y + i e^x \sin y$  is cts at each point of  $\mathbb{C}$

$f \rightarrow u \rightarrow \text{cts}$

$v \rightarrow \text{cts}$

Exercise. What can we say about discontinuity of  $\log z = \log r + i\theta$ ,  $\theta_0 < \theta \leq \theta_0 + 2\pi$

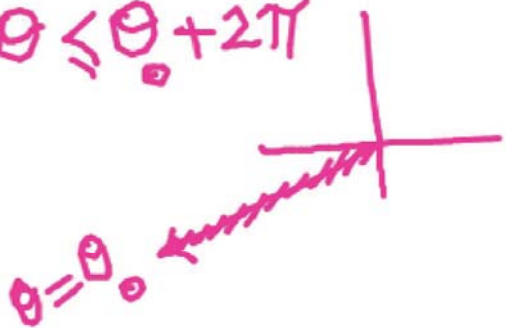

### Definition 3.1 Derivative of Complex Function

Suppose the complex function  $f$  is defined in a neighborhood of a point  $z_0$ . The derivative of  $f$  at  $z_0$ , denoted by  $f'(z_0)$ , is

$$f'(z_0) = \lim_{z \rightarrow z_0} \frac{f(z) - f(z_0)}{z - z_0} \quad (1)$$

provided this limit exists.

Theorem If  $f$  is der at  $z_0$ , then it is cts at  $z_0$ .

Proof.  $\lim_{z \rightarrow z_0} (f(z) - f(z_0)) = \lim_{z \rightarrow z_0} \left( \frac{f(z) - f(z_0)}{z - z_0} \cdot (z - z_0) \right) = \lim_{z \rightarrow z_0} \frac{f(z) - f(z_0)}{z - z_0} \cdot 0 = 0 \cdot 0 = 0 \quad \square$

### Theorem 3.4 Cauchy-Riemann Equations

Suppose  $f(z) = u(x, y) + iv(x, y)$  is differentiable at a point  $z = x + iy$ . Then at  $z$  the first-order partial derivatives of  $u$  and  $v$  exist and satisfy the **Cauchy-Riemann equations**

$$\frac{\partial u}{\partial x} = \frac{\partial v}{\partial y} \quad \text{and} \quad \frac{\partial u}{\partial y} = -\frac{\partial v}{\partial x}. \quad (1)$$

**Proof** The derivative of  $f$  at  $z$  is given by

$$f'(z) = \lim_{\Delta z \rightarrow 0} \frac{f(z + \Delta z) - f(z)}{\Delta z}. \quad (2)$$

By writing  $f(z) = u(x, y) + iv(x, y)$  and  $\Delta z = \Delta x + i\Delta y$ , (2) becomes

$$f'(z) = \lim_{\Delta z \rightarrow 0} \frac{u(x + \Delta x, y + \Delta y) + iv(x + \Delta x, y + \Delta y) - u(x, y) - iv(x, y)}{\Delta x + i\Delta y}. \quad (3)$$

Since the limit (2) is assumed to exist,  $\Delta z$  can approach zero from any convenient direction. In particular, if we choose to let  $\Delta z \rightarrow 0$  along a horizontal line, then  $\Delta y = 0$  and  $\Delta z = \Delta x$ . We can then write (3) as

$$\begin{aligned} f'(z) &= \lim_{\Delta x \rightarrow 0} \frac{u(x + \Delta x, y) - u(x, y) + i[v(x + \Delta x, y) - v(x, y)]}{\Delta x} \\ &= \lim_{\Delta x \rightarrow 0} \frac{u(x + \Delta x, y) - u(x, y)}{\Delta x} + i \lim_{\Delta x \rightarrow 0} \frac{v(x + \Delta x, y) - v(x, y)}{\Delta x}. \end{aligned} \quad (4)$$

The existence of  $f'(z)$  implies that each limit in (4) exists. These limits are the definitions of the first-order partial derivatives with respect to  $x$  of  $u$  and  $v$ , respectively. Hence, we have shown two things: both  $\partial u/\partial x$  and  $\partial v/\partial x$  exist at the point  $z$ , and that the derivative of  $f$  is

$$f'(z) = \frac{\partial u}{\partial x} + i \frac{\partial v}{\partial x}. \quad (5)$$

We now let  $\Delta z \rightarrow 0$  along a vertical line. With  $\Delta x = 0$  and  $\Delta z = i\Delta y$ , (3) becomes

$$f'(z) = \lim_{\Delta y \rightarrow 0} \frac{u(x, y + \Delta y) - u(x, y)}{i\Delta y} + i \lim_{\Delta y \rightarrow 0} \frac{v(x, y + \Delta y) - v(x, y)}{i\Delta y}. \quad (6)$$

In this case (6) shows us that  $\partial u/\partial y$  and  $\partial v/\partial y$  exist at  $z$  and that

$$f'(z) = -i \frac{\partial u}{\partial y} + \frac{\partial v}{\partial y}. \quad (7)$$

By equating the real and imaginary parts of (5) and (7) we obtain the pair of equations in (1). 

$$f = u + iv$$

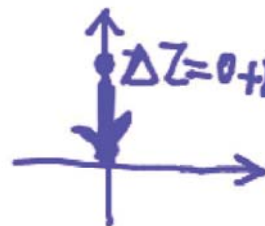
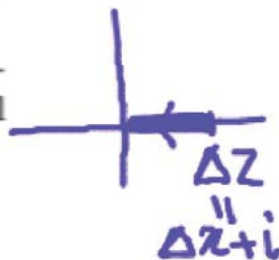

$f(z) = x + 4iy$  is not differentiable at any point  $z$ . If we identify  $u = x$  and  $v = 4y$ , then  $\partial u/\partial x = 1$ ,  $\partial v/\partial x = 0$ ,  $\partial u/\partial y = 0$ , and  $\partial v/\partial y = 4$ . In view of

$$\frac{\partial u}{\partial x} = 1 \neq \frac{\partial v}{\partial y} = 4$$

the two equations in (1) cannot be simultaneously satisfied at any point  $z$ . In other words,  $f$  is nowhere differentiable.

- We say  $f$  is analytic at  $z_0$  if



$f$  is differentiable at each point of some nbh of  $z_0$ .

- We say  $f$  is analytic on a domain  $D$  if  $f$  is analytic at each point of  $D$ .



$f(z) = \underbrace{x}_{u(x,y)} + 4i \underbrace{y}_{v(x,y)}$   
 $u: \mathbb{R}^2 \rightarrow \mathbb{R}$   
 $(x,y) \mapsto x$   
 $|x - x_0| \leq \sqrt{(x - x_0)^2 + (y - y_0)^2}$   
 Shows that  $u$  is Cts.

### A Sufficient Condition for Analyticity

By themselves, the

Cauchy-Riemann equations do not ensure analyticity of a function  $f(z) = u(x, y) + iv(x, y)$  at a point  $z = x + iy$ . It is possible for the Cauchy-Riemann equations to be satisfied at  $z$  and yet  $f(z)$  may not be differentiable at  $z$ , or  $f(z)$  may be differentiable at  $z$  but nowhere else. In either case,  $f$  is not analytic at  $z$ . See Problem 35 in Exercises 3.2. However, when we add the condition of continuity to  $u$  and  $v$  and to the four partial derivatives  $\partial u/\partial x$ ,  $\partial u/\partial y$ ,  $\partial v/\partial x$ , and  $\partial v/\partial y$ , it can be shown that the Cauchy-Riemann equations are not only necessary but also sufficient to guarantee analyticity of  $f(z) = u(x, y) + iv(x, y)$  at  $z$ . The proof is long and complicated and so we state only the result.

### Theorem 3.5 Criterion for Analyticity

Suppose the real functions  $u(x, y)$  and  $v(x, y)$  are continuous and have continuous first-order partial derivatives in a domain  $D$ . If  $u$  and  $v$  satisfy the Cauchy-Riemann equations (1) at all points of  $D$ , then the complex function  $f(z) = u(x, y) + iv(x, y)$  is analytic in  $D$ .

Example.

The function  $f(z) = \bar{z} = \underbrace{x}_u - i \underbrace{y}_v$

$$\frac{\partial u}{\partial x} = 1 \neq -1 = \frac{\partial v}{\partial y} \Rightarrow f \text{ is not diff at any point}$$

holomorphic

## Polar Coordinates

In Section 2.1 we saw that a complex function can be expressed in terms of polar coordinates. Indeed, the form  $f(z) = u(r, \theta) + iv(r, \theta)$  is often more convenient to use. In polar coordinates the Cauchy-Riemann equations become

$$\frac{\partial u}{\partial r} = \frac{1}{r} \frac{\partial v}{\partial \theta}, \quad \frac{\partial v}{\partial r} = -\frac{1}{r} \frac{\partial u}{\partial \theta}. \quad (10)$$

The polar version of (9) at a point  $z$  whose polar coordinates are  $(r, \theta)$  is then

$$f'(z) = e^{-i\theta} \left( \frac{\partial u}{\partial r} + i \frac{\partial v}{\partial r} \right) = \frac{1}{r} e^{-i\theta} \left( \frac{\partial v}{\partial \theta} - i \frac{\partial u}{\partial \theta} \right). \quad (11)$$

Handwritten derivation of the Cauchy-Riemann equations in polar coordinates:

$$\frac{\partial u}{\partial x} = \frac{\partial u}{\partial r} \cdot \frac{\partial r}{\partial x} + \frac{\partial u}{\partial \theta} \cdot \frac{\partial \theta}{\partial x}$$
$$\frac{\partial v}{\partial y} = \frac{\partial v}{\partial r} \cdot \frac{\partial r}{\partial y} + \frac{\partial v}{\partial \theta} \cdot \frac{\partial \theta}{\partial y}$$
$$\frac{\partial u}{\partial y} = -\frac{\partial v}{\partial x}$$

Conversion formulas:

$$r = \sqrt{x^2 + y^2} \Rightarrow \frac{\partial r}{\partial x} = \frac{x}{\sqrt{x^2 + y^2}}$$
$$\theta = \tan^{-1} \frac{y}{x}$$
$$\frac{\partial \theta}{\partial x} = \frac{-\frac{y}{x^2}}{1 + \frac{y^2}{x^2}} = \frac{-y}{x^2 + y^2}$$

Cauchy-Riemann equations in polar coordinates:

$$\frac{\partial u}{\partial r} = \frac{1}{r} \frac{\partial v}{\partial \theta}, \quad \frac{\partial v}{\partial r} = -\frac{1}{r} \frac{\partial u}{\partial \theta}$$

### EXAMPLE 3 Using Theorem 3.5

For the function  $f(z) = \frac{x}{x^2 + y^2} - i \frac{y}{x^2 + y^2}$ , the real functions  $u(x, y) = \frac{x}{x^2 + y^2}$  and  $v(x, y) = -\frac{y}{x^2 + y^2}$  are continuous except at the point where  $x^2 + y^2 = 0$ , that is, at  $z = 0$ . Moreover, the first four first-order partial derivatives

$$\frac{\partial u}{\partial x} = \frac{y^2 - x^2}{(x^2 + y^2)^2}, \quad \frac{\partial u}{\partial y} = -\frac{2xy}{(x^2 + y^2)^2},$$

$$\frac{\partial v}{\partial x} = \frac{2xy}{(x^2 + y^2)^2}, \quad \text{and} \quad \frac{\partial v}{\partial y} = \frac{y^2 - x^2}{(x^2 + y^2)^2}$$

are continuous except at  $z = 0$ . Finally, we see from

$$\frac{\partial u}{\partial x} = \frac{y^2 - x^2}{(x^2 + y^2)^2} = \frac{\partial v}{\partial y} \quad \text{and} \quad \frac{\partial u}{\partial y} = -\frac{2xy}{(x^2 + y^2)^2} = -\frac{\partial v}{\partial x}$$

that the Cauchy-Riemann equations are satisfied except at  $z = 0$ . Thus we conclude from Theorem 3.5 that  $f$  is analytic in any domain  $D$  that does not contain the point  $z = 0$ .

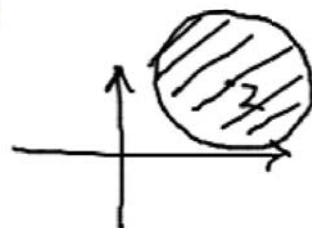

### Sufficient Conditions for Differentiability

If the real functions  $u(x, y)$  and  $v(x, y)$  are continuous and have continuous first-order partial derivatives in some neighborhood of a point  $z$ , and if  $u$  and  $v$  satisfy the Cauchy-Riemann equations (1) at  $z$ , then the complex function  $f(z) = u(x, y) + iv(x, y)$  is differentiable at  $z$  and  $f'(z)$  is given by

$$f'(z) = \frac{\partial u}{\partial x} + i \frac{\partial v}{\partial x} = \frac{\partial v}{\partial y} - i \frac{\partial u}{\partial y}$$

### EXAMPLE 4 A Function Differentiable on a Line

In Example 2 we saw that the complex function  $f(z) = 2x^2 + y + i(y^2 - x)$  was nowhere analytic, but yet the Cauchy-Riemann equations were satisfied on the line  $y = 2x$ . But since the functions  $u(x, y) = 2x^2 + y$ ,  $\partial u/\partial x = 4x$ ,  $\partial u/\partial y = 1$ ,  $v(x, y) = y^2 - x$ ,  $\partial v/\partial x = -1$  and  $\partial v/\partial y = 2y$  are continuous at every point, it follows that  $f$  is differentiable on the line  $y = 2x$ . Moreover, from (9) we see that the derivative of  $f$  at points on this line is given by  $f'(z) = 4x - i = 2y - i$ .

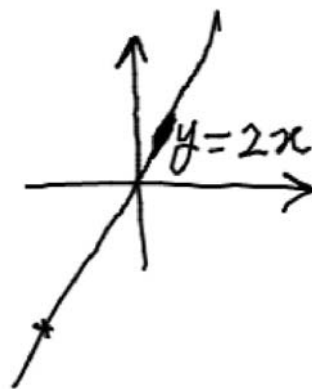

The following theorem is a direct consequence of the Cauchy-Riemann equations. Its proof is left as an exercise. See Problems 29 and 30 in Exercises 3.2.

$f: \mathbb{R} \rightarrow \mathbb{R}$   
 $f(x) = c$   
 $\Rightarrow f'(x) = 0$  for all intervals

### Theorem 3.6 Constant Functions

Suppose the function  $f(z) = u(x, y) + iv(x, y)$  is analytic in a domain  $D$ .

(i) If  $|f(z)|$  is constant in  $D$ , then so is  $f(z)$ . (why?)

(ii) If  $f'(z) = 0$  in  $D$ , then  $f(z) = c$  in  $D$ , where  $c$  is a constant.

$f'(z) = \frac{\partial u}{\partial x} + i \frac{\partial v}{\partial x} = 0 \Rightarrow \frac{\partial u}{\partial x} = 0 \Rightarrow u(x, y) = \varphi(y) \Rightarrow \frac{\partial u}{\partial y} = \varphi'(y) \Rightarrow \frac{\partial v}{\partial x} = \varphi'(y) \Rightarrow \frac{\partial v}{\partial y} = \varphi''(y)$



$$\frac{\partial^2 \phi}{\partial x^2} + \frac{\partial^2 \phi}{\partial y^2} = 0. \quad (1)$$

This equation, one of the most famous in applied mathematics, is known as **Laplace's equation** in two variables. The sum  $\frac{\partial^2 \phi}{\partial x^2} + \frac{\partial^2 \phi}{\partial y^2}$  of the two second partial derivatives in (1) is denoted by  $\nabla^2 \phi$  and is called the **Laplacian** of  $\phi$ . Laplace's equation is then abbreviated as  $\nabla^2 \phi = 0$ .

**Harmonic Functions** A solution  $\phi(x, y)$  of Laplace's equation (1) in a domain  $D$  of the plane is given a special name.

### Definition 3.3 Harmonic Functions

A real-valued function  $\phi$  of two real variables  $x$  and  $y$  that has continuous first and second-order partial derivatives in a domain  $D$  and satisfies Laplace's equation is said to be **harmonic** in  $D$ .

### Theorem 3.7 Harmonic Functions

Suppose the complex function  $f(z) = u(x, y) + iv(x, y)$  is analytic in a domain  $D$ . Then the functions  $u(x, y)$  and  $v(x, y)$  are harmonic in  $D$ .

**Proof** Assume  $f(z) = u(x, y) + iv(x, y)$  is analytic in a domain  $D$  and that  $u$  and  $v$  have continuous second-order partial derivatives in  $D$ .<sup>†</sup> Since  $f$  is analytic, the Cauchy-Riemann equations are satisfied at every point  $z$ . Differentiating both sides of  $\partial u / \partial x = \partial v / \partial y$  with respect to  $x$  and differentiating both sides of  $\partial u / \partial y = -\partial v / \partial x$  with respect to  $y$  give, respectively,

$$\frac{\partial^2 u}{\partial x^2} = \frac{\partial^2 v}{\partial x \partial y} \quad \text{and} \quad \frac{\partial^2 u}{\partial y^2} = -\frac{\partial^2 v}{\partial y \partial x}. \quad (2)$$

With the assumption of continuity, the mixed partials  $\partial^2 v / \partial x \partial y$  and  $\partial^2 v / \partial y \partial x$  are equal. Hence, by adding the two equations in (2) we see that

$$\frac{\partial^2 u}{\partial x^2} + \frac{\partial^2 u}{\partial y^2} = 0 \quad \text{or} \quad \nabla^2 u = 0. \quad \& \text{ Similarly } \nabla^2 v = 0. \quad \square$$

### EXAMPLE 1 Harmonic Functions

The function  $f(z) = z^2 = x^2 - y^2 + 2xyi$  is entire. The functions  $u(x, y) = x^2 - y^2$  and  $v(x, y) = 2xy$  are necessarily harmonic in any domain  $D$  of the complex plane.



### Harmonic Conjugate Functions

We have just shown that if a function  $f(z) = u(x, y) + iv(x, y)$  is analytic in a domain  $D$ , then its real and imaginary parts  $u$  and  $v$  are necessarily harmonic in  $D$ . Now suppose  $u(x, y)$  is a given real function that is known to be harmonic in  $D$ . If it is possible to find another real harmonic function  $v(x, y)$  so that  $u$  and  $v$  satisfy the Cauchy-Riemann equations throughout the domain  $D$ , then the function  $v(x, y)$  is called a **harmonic conjugate** of  $u(x, y)$ . By combining the functions as  $u(x, y) + iv(x, y)$  we obtain a function that is analytic in  $D$ .

*If  $f$  is analytic in  $D$ , then  $u$  &  $v$  and all of their partial derivatives are cts.*

*Given  $u$ ,  
 $\exists v$ ;  $u + iv$  is analytic.*

### Theorem 4.1 Analyticity of $e^z$

The exponential function  $e^z$  is entire and its derivative is given by:

$$\frac{d}{dz}e^z = e^z. \quad (3)$$

**Proof** In order to establish that  $e^z$  is entire, we use the criterion for analyticity given in Theorem 3.5. We first note that the real and imaginary parts,  $u(x, y) = e^x \cos y$  and  $v(x, y) = e^x \sin y$ , of  $e^z$  are continuous real functions and have continuous first-order partial derivatives for all  $(x, y)$ . In addition, the Cauchy-Riemann equations in  $u$  and  $v$  are easily verified:

$$\frac{\partial u}{\partial x} = e^x \cos y = \frac{\partial v}{\partial y} \quad \text{and} \quad \frac{\partial u}{\partial y} = -e^x \sin y = -\frac{\partial v}{\partial x}.$$

Therefore, the exponential function  $e^z$  is entire by Theorem 3.5. By (9) of Section 3.2, the derivative of an analytic function  $f$  is given by  $f'(z) = \frac{\partial u}{\partial x} + i\frac{\partial v}{\partial x}$ , and so the derivative of  $e^z$  is:

$$\frac{d}{dz}e^z = \frac{\partial u}{\partial x} + i\frac{\partial v}{\partial x} = e^x \cos y + ie^x \sin y = e^z. \quad \text{✎}$$

$$\frac{\partial v}{\partial y} = 3x^2 - 3y^2 \quad \text{and} \quad \frac{\partial v}{\partial x} = 6xy + 5. \quad (3)$$

Partial integration of the first equation in (3) with respect to the variable  $y$  gives  $v(x, y) = 3x^2y - y^3 + h(x)$ . The partial derivative with respect to  $x$  of this last equation is

$$\frac{\partial v}{\partial x} = 6xy + h'(x).$$

When this result is substituted into the second equation in (3) we obtain  $h'(x) = 5$ , and so  $h(x) = 5x + C$ , where  $C$  is a real constant. Therefore, the harmonic conjugate of  $u$  is  $v(x, y) = 3x^2y - y^3 + 5x + C$ .

### Theorem 4.1 Analyticity of $e^z$

The exponential function  $e^z$  is entire and its derivative is given by:

$$\frac{d}{dz}e^z = e^z. \quad (3)$$

**Proof** In order to establish that  $e^z$  is entire, we use the criterion for analyticity given in Theorem 3.5. We first note that the real and imaginary parts,  $u(x, y) = e^x \cos y$  and  $v(x, y) = e^x \sin y$ , of  $e^z$  are continuous real functions and have continuous first-order partial derivatives for all  $(x, y)$ . In addition, the Cauchy-Riemann equations in  $u$  and  $v$  are easily verified:

$$\frac{\partial u}{\partial x} = e^x \cos y = \frac{\partial v}{\partial y} \quad \text{and} \quad \frac{\partial u}{\partial y} = -e^x \sin y = -\frac{\partial v}{\partial x}.$$

Therefore, the exponential function  $e^z$  is entire by Theorem 3.5. ~~By~~

$$\begin{aligned} \frac{d}{dz}e^z &= \frac{\partial u}{\partial x} + i\frac{\partial v}{\partial x} \\ &= e^x \cos y + ie^x \sin y \\ &= e^z \end{aligned}$$

**Modulus, Argument, and Conjugate** The modulus, argument, and conjugate of the exponential function are easily determined from (1). If we express the complex number  $w = e^z$  in polar form:

$$w = e^x \cos y + ie^x \sin y = r (\cos \theta + i \sin \theta),$$

then we see that  $r = e^x$  and  $\theta = y + 2n\pi$ , for  $n = 0, \pm 1, \pm 2, \dots$ . Because  $r$  is the modulus and  $\theta$  is an argument of  $w$ , we have:

$$|e^z| = e^x \quad (4)$$

$$\text{and} \quad \arg(e^z) = y + 2n\pi, \quad n = 0, \pm 1, \pm 2, \dots \quad (5)$$

We know from calculus that  $e^x > 0$  for all real  $x$ , and so it follows from (4) that  $|e^z| > 0$ . This implies that  $e^z \neq 0$  for all complex  $z$ . Put another way, the point  $w = 0$  is not in the range of the complex function  $w = e^z$ . Equation (4) does not, however, rule out the possibility that  $e^z$  is a negative real number. In fact, you should verify that if, say,  $z = \pi i$ , then  $e^{\pi i}$  is real and  $e^{\pi i} < 0$ .

A formula for the conjugate of the complex exponential  $e^z$  is found using properties of the real cosine and sine functions. Since the real cosine function is even, we have  $\cos y = \cos(-y)$  for all  $y$ , and since the real sine function is odd, we have  $-\sin y = \sin(-y)$  for all  $y$ , and so:

$$\overline{e^z} = e^x \cos y - ie^x \sin y = e^x \cos(-y) + ie^x \sin(-y) = e^{x-iy} = e^{\bar{z}}.$$

Therefore, for all complex  $z$ , we have shown:

$$\overline{e^z} = e^{\bar{z}}. \quad (6)$$

#### Theorem 4.2 Algebraic Properties of $e^z$

If  $z_1$  and  $z_2$  are complex numbers, then

$$(i) \quad e^0 = 1$$

$$(ii) \quad e^{z_1} e^{z_2} = e^{z_1+z_2}$$

$$(iii) \quad \frac{e^{z_1}}{e^{z_2}} = e^{z_1-z_2}$$

$$(iv) \quad (e^{z_1})^n = e^{nz_1}, \quad n = 0, \pm 1, \pm 2, \dots$$

**Periodicity** The most striking difference between the real and complex exponential functions is the periodicity of  $e^z$ . Analogous to real periodic functions, we say that a complex function  $f$  is **periodic** with period  $T$  if  $f(z + T) = f(z)$  for all complex  $z$ . The real exponential function is not periodic, but the complex exponential function is because it is defined using the real cosine and sine functions, which are periodic. In particular, by (1) and Theorem 4.2(ii) we have  $e^{z+2\pi i} = e^z e^{2\pi i} = e^z (\cos 2\pi + i \sin 2\pi)$ . Since  $\cos 2\pi = 1$  and  $\sin 2\pi = 0$ , this simplifies to:

$$e^{z+2\pi i} = e^z. \quad (8)$$

In summary, we have shown that:

*The complex exponential function  $e^z$  is periodic with a pure imaginary period  $2\pi i$ .*

## Exponential Mapping Properties

- (i)  $w = e^z$  maps the fundamental region  $-\infty < x < \infty$ ,  $-\pi < y \leq \pi$ , onto the set  $|w| > 0$ .
- (ii)  $w = e^z$  maps the vertical line segment  $x = a$ ,  $-\pi < y \leq \pi$ , onto the circle  $|w| = e^a$ .
- (iii)  $w = e^z$  maps the horizontal line  $y = b$ ,  $-\infty < x < \infty$ , onto the ray  $\arg(w) = b$ .

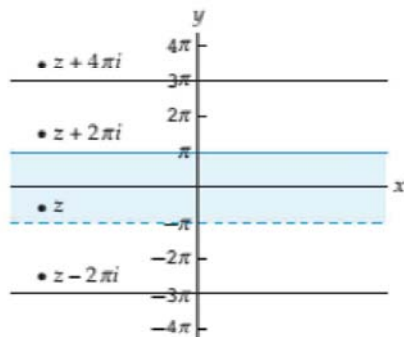
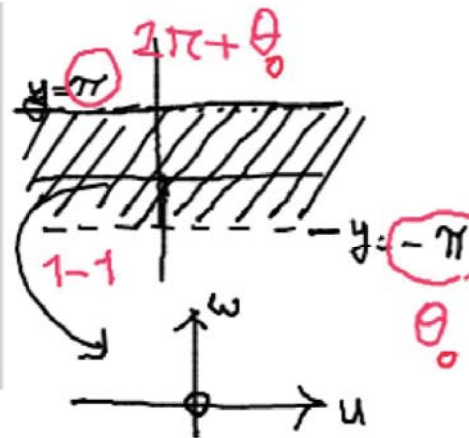

Figure 4.1 The fundamental region

$e^z$  is not a one-to-one function on its domain  $\mathbf{C}$ . In fact, given a fixed nonzero complex number  $z$ , the equation  $e^w = z$  has infinitely many solutions. For example, you should verify that  $\frac{1}{2}\pi i$ ,  $\frac{5}{2}\pi i$ , and  $-\frac{3}{2}\pi i$  are all solutions to the equation  $e^w = i$ . To see why the equation  $e^w = z$  has infinitely many solutions in general, suppose that  $w = u + iv$  is a solution of  $e^w = z$ . Then we must have  $|e^w| = |z|$  and  $\arg(e^w) = \arg(z)$ . From (4) and (5), it follows that  $e^u = |z|$  and  $v = \arg(z)$ , or, equivalently,  $u = \log_e |z|$  and  $v = \arg(z)$ . Therefore, given a nonzero complex number  $z$  we have shown that:

$$\text{If } e^w = z, \text{ then } w = \log_e |z| + i \arg(z). \quad (10)$$

Because there are infinitely many arguments of  $z$ , (10) gives infinitely many solutions  $w$  to the equation  $e^w = z$ . The set of values given by (10) defines a multiple-valued function  $w = G(z)$ , as described in Section 2.4, which is called the complex logarithm of  $z$  and denoted by  $\ln z$ . The following definition summarizes this discussion.

### Definition 4.2 Complex Logarithm

The multiple-valued function  $\ln z$  defined by:

$$\ln z = \log_e |z| + i \arg(z) \quad (11)$$

is called the **complex logarithm**.

The converse of the exp function is a function  $w = f(z)$ . So

$$z = e^w \\ r \text{cis} \theta = e^u \text{cis} v$$

$$r = e^u \Rightarrow u = \log_e r = \ln r$$

$$\theta = 2k\pi + v \Rightarrow v = \theta$$

$$w = \ln r + i\theta$$

$$(z = re^{i\theta}, \theta_0 \leq \theta \leq \theta_0 + 2\pi)$$

$\log z \rightarrow$  it depends on  $\theta_0$

By changing  $\theta_0$ , we get other branches of  $\log z$ .

$$y = f(x) \Leftrightarrow x = f^{-1}(y)$$

### EXAMPLE 4 Principal Value of the Complex Logarithm

Compute the principal value of the complex logarithm  $\text{Ln } z$  for

- (a)  $z = i$                       (b)  $z = 1 + i$                       (c)  $z = -2$

**Solution** In each part we apply (14) of Definition 4.3.

(a) For  $z = i$ , we have  $|z| = 1$  and  $\text{Arg}(z) = \pi/2$ , and so:

$$\text{Log } i = \text{Ln } i = \log_e 1 + \frac{\pi}{2}i.$$

However, since  $\log_e 1 = 0$ , this simplifies to:

$$\text{Ln } i = \frac{\pi}{2}i.$$



### Theorem 4.4 Analyticity of the Principal Branch of $\ln z$

The principal branch  $f_1$  of the complex logarithm defined by (19) is an analytic function and its derivative is given by:

$$f_1'(z) = \frac{1}{z}. \tag{20}$$

**proof** We prove that  $f_1$  is analytic by using the polar coordinate analogue to theorem 3.5 of Section 3.2. Because  $f_1$  is defined on the domain given in (18),  $z$  is a point in this domain, then we can write  $z = re^{i\theta}$  with  $-\pi < \theta < \pi$ . Since the real and imaginary parts of  $f_1$  are  $u(r, \theta) = \log_e r$  and  $v(r, \theta) = \theta$ , respectively, we find that:

$$\begin{aligned} \frac{\partial u}{\partial r} &= \frac{1}{r}, & \frac{\partial v}{\partial \theta} &= 1, \\ \frac{\partial v}{\partial r} &= 0, & \text{and } \frac{\partial u}{\partial \theta} &= 0. \end{aligned}$$

Thus,  $u$  and  $v$  satisfy the Cauchy-Riemann equations in polar coordinates (10) in Section 3.2:

$$\frac{\partial u}{\partial r} = \frac{1}{r} \frac{\partial v}{\partial \theta} \quad \text{and} \quad \frac{\partial v}{\partial r} = -\frac{1}{r} \frac{\partial u}{\partial \theta}.$$

Because  $u$ ,  $v$ , and the first partial derivatives of  $u$  and  $v$  are continuous at all points in the domain given in (18), it follows from Theorem 3.5 that  $f_1$  is analytic in this domain. In addition, from (11) of Section 3.2, the derivative of  $f_1$  is given by:

$$f_1'(z) = e^{-i\theta} \left( \frac{\partial u}{\partial r} + i \frac{\partial v}{\partial r} \right) = \frac{1}{re^{i\theta}} = \frac{1}{z}.$$

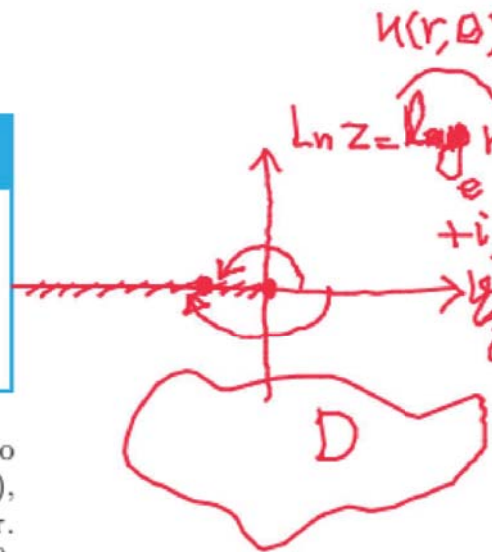

### Definition 4.6 Complex Sine and Cosine Functions

The complex **sine** and **cosine** functions are defined by:

$$\sin z = \frac{e^{iz} - e^{-iz}}{2i} \quad \text{and} \quad \cos z = \frac{e^{iz} + e^{-iz}}{2}. \tag{4}$$

The complex **hyperbolic sine** and **hyperbolic cosine** functions are defined by:

$$\begin{aligned} \sinh z &= \frac{e^z - e^{-z}}{2} \\ \cosh z &= \frac{e^z + e^{-z}}{2} \end{aligned}$$

Note: We cannot define an order like the usual " $\leq$ " on  $\mathbb{R}$  on  $\mathbb{C}$ , since if there were such an order, then we would have  $i > 0, i < 0, \text{ or } i = 0$

$i > 0 \rightarrow i \cdot i > 0$   
 $i < 0 \rightarrow -i > 0, -i > 0 \rightarrow (-i)(-i) > 0$   
 $i = 0$  is crossed out.  
 impossible

Def.  $\int_a^b f(t) dt := \int_a^b u(t) dt + i \int_a^b v(t) dt$   
 where  $f(t) = u(t) + iv(t)$

Note:  $\text{Re} \int f(z) dz = \int \text{Re} f(z) dx - \text{Im} f(z) dy$   
 Complex integral (Smooth) are cts  $x(t) & y(t)$

Let us see a have a function  $f$  and a curve

$C : \begin{cases} x = x(t) \\ y = y(t) \end{cases}$   
 $z(t) = x(t) + iy(t)$

$\oint_C f(z) dz = \int_a^b f(z(t)) z'(t) dt$

equivalently  $\lim_{\|P\| \rightarrow 0} \sum_{k=1}^n f(z_k^*) \Delta z_k$

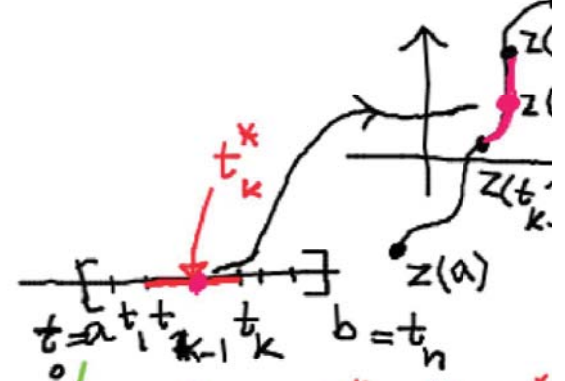

$\forall \epsilon > 0 \exists \delta > 0 \forall \{t_0^*, \dots, t_n^*\} \forall \{t_0, \dots, t_n\} \left( \|P\| < \delta \Rightarrow \left| \sum_{k=1}^n f(z_k^*) \Delta z_k - \int_C f(z) dz \right| < \epsilon \right)$

$z_k^* = x(t_k^*) + iy(t_k^*)$   
 $\Delta z_k = z(t_k) - z(t_{k-1})$

Partition  $P = \{t_0, \dots, t_n\}, t_0 < t_1 < \dots < t_n = b$

$\|P\| = \max_{1 \leq j \leq n} |t_j - t_{j-1}|$

Th.  $\oint_C (kf + mg) dz = k \oint_C f dz + m \oint_C g dz$

Example:  $\oint_C z dz$  where  $z(t) = 3t + it^2, -4 \leq t \leq 4$   
 $= \int_{-4}^4 (3t - it^2)(3 + 2ti) dt = \dots$

## Steps Leading to the Definition of the Definite Integral

1. Let  $f$  be a function of a single variable  $x$  defined at all points in a closed interval  $[a, b]$ .
2. Let  $P$  be a partition:

$$a = x_0 < x_1 < x_2 < \dots < x_{n-1} < x_n = b$$

of  $[a, b]$  into  $n$  subintervals  $[x_{k-1}, x_k]$  of length  $\Delta x_k = x_k - x_{k-1}$ . See Figure 5.1.

3. Let  $\|P\|$  be the **norm** of the partition  $P$  of  $[a, b]$ , that is, the length of the longest subinterval.  $\|P\| = \max_{1 \leq k \leq n} \Delta x_k$
4. Choose a number  $x_k^*$  in each subinterval  $[x_{k-1}, x_k]$  of  $[a, b]$ . See Figure 5.1.
5. Form  $n$  products  $f(x_k^*)\Delta x_k$ ,  $k = 1, 2, \dots, n$ , and then sum these products:

$$\sum_{k=1}^n f(x_k^*) \Delta x_k$$

a Riemann sum

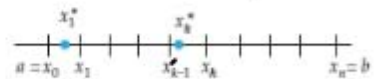
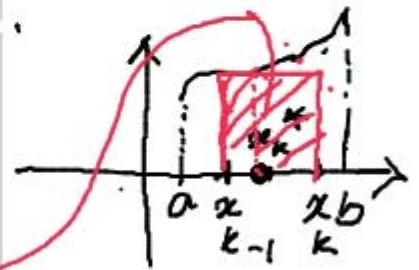

Figure 5.1 Partition of  $[a, b]$  with  $x_k^*$  in each subinterval  $[x_{k-1}, x_k]$



### Definition 5.1 Definite Integral

The definite integral of  $f$  on  $[a, b]$  is

$$\int_a^b f(x) dx = \lim_{\|P\| \rightarrow 0} \sum_{k=1}^n f(x_k^*) \Delta x_k \quad (2)$$

$\forall \epsilon > 0, \exists \delta > 0, \|P\| < \delta \Rightarrow \left| \sum_{k=1}^n f(x_k^*) \Delta x_k - A \right| < \epsilon$

### Terminology

Suppose a curve  $C$  in the plane is parametrized by a set of equations  $x = x(t)$ ,  $y = y(t)$ ,  $a \leq t \leq b$ , where  $x(t)$  and  $y(t)$  are continuous real functions. Let the **initial** and **terminal** points of  $C$ , that is,  $(x(a), y(a))$  and  $(x(b), y(b))$ , be denoted by the symbols  $A$  and  $B$ , respectively. We say that:

- $C$  is a **smooth curve** if  $x'$  and  $y'$  are continuous on the closed interval  $[a, b]$  and not simultaneously zero on the open interval  $(a, b)$ .
- $C$  is a **piecewise smooth curve** if it consists of a finite number of smooth curves  $C_1, C_2, \dots, C_n$  joined end to end, that is, the terminal point of one curve  $C_k$  coinciding with the initial point of the next curve  $C_{k+1}$ .
- $C$  is a **simple curve** if the curve  $C$  does not cross itself except possibly at  $t = a$  and  $t = b$ .
- $C$  is a **closed curve** if  $A = B$ .
- $C$  is a **simple closed curve** if the curve  $C$  does not cross itself and  $A = B$ ; that is,  $C$  is simple and closed.

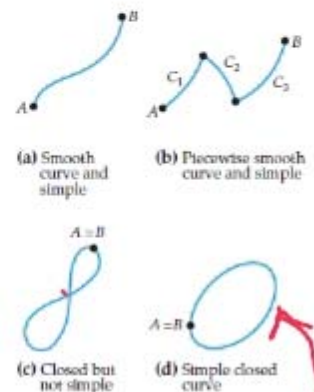

Figure 5.2 Types of curves in the plane

## Steps Leading to the Definition of Line Integrals

1. Let  $G$  be a function of two real variables  $x$  and  $y$  defined at all points on a smooth curve  $C$  that lies in some region of the  $xy$ -plane. Let  $C$  be defined by the parametrization  $x = x(t)$ ,  $y = y(t)$ ,  $a \leq t \leq b$ .
2. Let  $P$  be a partition of the parameter interval  $[a, b]$  into  $n$  subintervals  $[t_{k-1}, t_k]$  of length  $\Delta t_k = t_k - t_{k-1}$ :

$$a = t_0 < t_1 < t_2 < \dots < t_{n-1} < t_n = b.$$

The partition  $P$  induces a partition of the curve  $C$  into  $n$  subarcs of length  $\Delta s_k$ . Let the projection of each subarc onto the  $x$ - and  $y$ -axes have lengths  $\Delta x_k$  and  $\Delta y_k$ , respectively. See Figure 5.3.

3. Let  $\|P\|$  be the norm of the partition  $P$  of  $[a, b]$ , that is, the length of the longest subinterval.
4. Choose a point  $(x_k^*, y_k^*)$  on each subarc of  $C$ . See Figure 5.3.
5. Form  $n$  products  $G(x_k^*, y_k^*)\Delta x_k$ ,  $G(x_k^*, y_k^*)\Delta y_k$ ,  $G(x_k^*, y_k^*)\Delta s_k$ ,  $k = 1, 2, \dots, n$ , and then sum these products

$$\sum_{k=1}^n G(x_k^*, y_k^*)\Delta x_k, \quad \sum_{k=1}^n G(x_k^*, y_k^*)\Delta y_k, \quad \text{and} \quad \sum_{k=1}^n G(x_k^*, y_k^*)\Delta s_k.$$

### Definition 5.2 Line Integrals in the Plane

(i) The line integral of  $G$  along  $C$  with respect to  $x$  is

$$\int_C G(x, y) dx = \lim_{\|P\| \rightarrow 0} \sum_{k=1}^n G(x_k^*, y_k^*) \Delta x_k.$$

(ii) The line integral of  $G$  along  $C$  with respect to  $y$  is

$$\int_C G(x, y) dy = \lim_{\|P\| \rightarrow 0} \sum_{k=1}^n G(x_k^*, y_k^*) \Delta y_k.$$

(iii) The line integral of  $G$  along  $C$  with respect to arc length  $s$  is

$$\int_C G(x, y) ds = \lim_{\|P\| \rightarrow 0} \sum_{k=1}^n G(x_k^*, y_k^*) \Delta s_k.$$

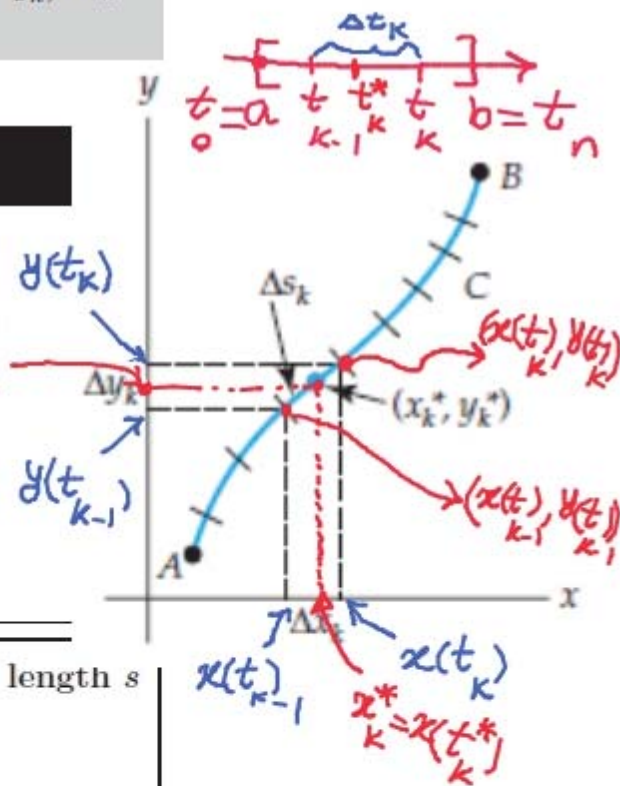



## Method of Evaluation— $C$ Defined Parametrically

The line integrals in Definition 5.2 can be evaluated in two ways, depending on whether the curve  $C$  is defined by a pair of parametric equations or by an explicit function. Either way, *the basic idea is to convert a line integral to a definite integral* in a single variable. If  $C$  is smooth curve parametrized by  $x = x(t)$ ,  $y = y(t)$ ,  $a \leq t \leq b$ , then replace  $x$  and  $y$  in the integral by the functions  $x(t)$  and  $y(t)$ , and the appropriate differential  $dx$ ,  $dy$ , or  $ds$  by

$$x'(t) dt, \quad y'(t) dt, \quad \text{or} \quad \sqrt{[x'(t)]^2 + [y'(t)]^2} dt.$$

The term  $ds = \sqrt{[x'(t)]^2 + [y'(t)]^2} dt$  is called the differential of the arc length. In this manner each of the line integrals in Definition 5.2 becomes a definite integral in which the variable of integration is the parameter  $t$ . That is,

$$\int_C G(x, y) dx = \int_a^b G(x(t), y(t)) x'(t) dt, \quad (6)$$

$$\int_C G(x, y) dy = \int_a^b G(x(t), y(t)) y'(t) dt, \quad (7)$$

$$\int_C G(x, y) ds = \int_a^b G(x(t), y(t)) \sqrt{[x'(t)]^2 + [y'(t)]^2} dt. \quad (8)$$

Handwritten notes in red:

- $\sum x = x(t)$
- $\sum dx = x'(t) dt$
- $ds = \sqrt{x'(t)^2 + y'(t)^2} dt$
- A diagram showing a small right triangle with sides  $dx$  and  $dy$  and hypotenuse  $ds$ . The hypotenuse is labeled  $y+dy$  and the horizontal side is labeled  $x$  to  $x+dx$ .
- $ds = \sqrt{dx^2 + dy^2}$
- $= \sqrt{x'(t)^2 + y'(t)^2} dt$

### EXAMPLE 1 $C$ Defined Parametrically

Evaluate (a)  $\int_C xy^2 dx$ , (b)  $\int_C xy^2 dy$ , and (c)  $\int_C xy^2 ds$ , where the path of integration  $C$  is the quarter circle defined by  $x = 4 \cos t$ ,  $y = 4 \sin t$ ,  $0 \leq t \leq \pi/2$ .

Handwritten note in red:  $dx = -4 \sin t dt$

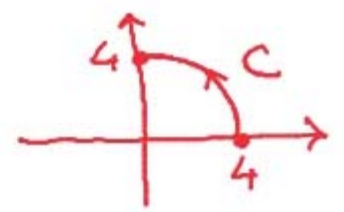

**Solution** The path  $C$  of integration is shown in color in Figure 5.4. In each of the three given line integrals,  $x$  is replaced by  $4 \cos t$  and  $y$  is replaced by  $4 \sin t$ .

(a) Since  $dx = -4 \sin t dt$ , we have from (6):

$$\begin{aligned} \int_C xy^2 dx &= \int_0^{\pi/2} (4 \cos t) (4 \sin t)^2 (-4 \sin t dt) \\ &= -256 \int_0^{\pi/2} \sin^3 t \cos t dt = -256 \left[ \frac{1}{4} \sin^4 t \right]_0^{\pi/2} = -64. \end{aligned}$$

(b) Similar to (a).

(c) Since  $ds = \sqrt{16 (\sin^2 t + \cos^2 t)} dt = 4 dt$ , it follows from (8):

$$\begin{aligned} \int_C xy^2 ds &= \int_0^{\pi/2} (4 \cos t) (4 \sin t)^2 (4 dt) \\ &= 256 \int_0^{\pi/2} \sin^2 t \cos t dt = 256 \left[ \frac{1}{3} \sin^3 t \right]_0^{\pi/2} = \frac{256}{3}. \end{aligned}$$

## Method of Evaluation— $C$ Defined Parametrically

The line integrals in Definition 5.2 can be evaluated in two ways, depending on whether the curve  $C$  is defined by a pair of parametric equations or by an explicit function. Either way, *the basic idea is to convert a line integral to a definite integral* in a single variable. If  $C$  is smooth curve parametrized by  $x = x(t)$ ,  $y = y(t)$ ,  $a \leq t \leq b$ , then replace  $x$  and  $y$  in the integral by the functions  $x(t)$  and  $y(t)$ , and the appropriate differential  $dx$ ,  $dy$ , or  $ds$  by

$$x'(t) dt, \quad y'(t) dt, \quad \text{or} \quad \sqrt{[x'(t)]^2 + [y'(t)]^2} dt.$$

The term  $ds = \sqrt{[x'(t)]^2 + [y'(t)]^2} dt$  is called the differential of the arc length. In this manner each of the line integrals in Definition 5.2 becomes a definite integral in which the variable of integration is the parameter  $t$ . That is,

$$\int_C G(x, y) dx = \int_a^b G(x(t), y(t)) x'(t) dt, \quad (6)$$

$$\int_C G(x, y) dy = \int_a^b G(x(t), y(t)) y'(t) dt, \quad (7)$$

$$\int_C G(x, y) ds = \int_a^b G(x(t), y(t)) \sqrt{[x'(t)]^2 + [y'(t)]^2} dt. \quad (8)$$

### EXAMPLE 1 $C$ Defined Parametrically

Evaluate (a)  $\int_C xy^2 dx$ , (b)  $\int_C xy^2 dy$ , and (c)  $\int_C xy^2 ds$ , where the path of integration  $C$  is the quarter circle defined by  $x = 4 \cos t$ ,  $y = 4 \sin t$ ,  $0 \leq t \leq \pi/2$ .

**Solution** The path  $C$  of integration is shown in color in Figure 5.4. In each of the three given line integrals,  $x$  is replaced by  $4 \cos t$  and  $y$  is replaced by  $4 \sin t$ .

(a) Since  $dx = -4 \sin t dt$ , we have from (6):

$$\begin{aligned} \int_C xy^2 dx &= \int_0^{\pi/2} (4 \cos t) (4 \sin t)^2 (-4 \sin t dt) \\ &= -256 \int_0^{\pi/2} \sin^3 t \cos t dt = -256 \left[ \frac{1}{4} \sin^4 t \right]_0^{\pi/2} = -64. \end{aligned}$$

## Method of Evaluation— $C$ Defined by a Function

If the path of integration  $C$  is the graph of an explicit function  $y = f(x)$ ,  $a \leq x \leq b$ , then we can use  $x$  as a parameter. In this situation, the differential of  $y$  is  $dy = f'(x) dx$ , and the differential of arc length is  $ds = \sqrt{1 + [f'(x)]^2} dx$ . After substituting, the three line integrals of Definition 5.2 become, in turn, the definite integrals:

$$\int_a^b G(x(t), y(t)) x'(t) dt = \int_a^b G(t, f(t)) 1 dt$$

$$y = f(x) \quad \int_C G(x, y) dx = \int_a^b G(x, f(x)) dx, \quad (9)$$

$$x = t \quad \int_C G(x, y) dy = \int_a^b G(x, f(x)) f'(x) dx, \quad (10)$$

$$y = f(t) \quad \int_C G(x, y) ds = \int_a^b G(x, f(x)) \sqrt{1 + [f'(x)]^2} dx. \quad (11)$$

$$\begin{aligned} ds &= \sqrt{dx^2 + dy^2} \\ &= \sqrt{dx^2 + f'(x)^2 dx^2} \\ &= \sqrt{1 + f'(x)^2} dx \end{aligned}$$

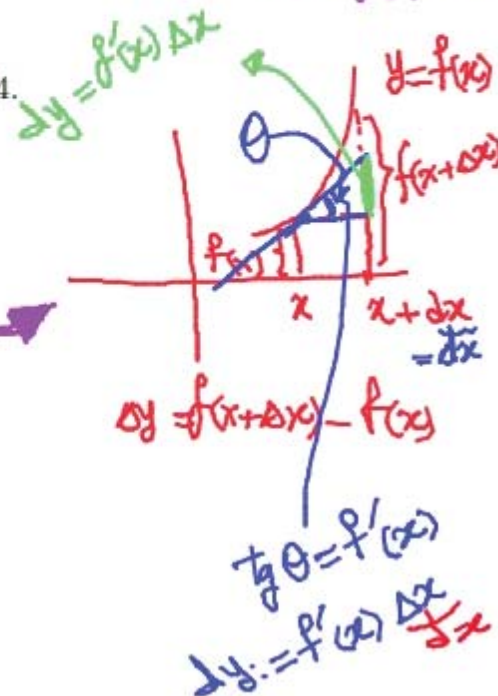

### Notation

In many applications, line integrals appear as a sum  $\int_C P(x, y) dx + \int_C Q(x, y) dy$ . It is common practice to write this sum as one integral without parentheses as

$$:= \int_C P(x, y) dx + Q(x, y) dy \quad \text{or simply} \quad \int_C P dx + Q dy. \quad (13)$$

A line integral along a closed curve  $C$  is usually denoted by

$$\oint_C P dx + Q dy.$$

### EXAMPLE 2 $C$ Defined by an Explicit Function

Evaluate  $\int_C xy dx + x^2 dy$ , where  $C$  is the graph of  $y = x^3$ ,  $-1 \leq x \leq 2$ .

**Solution** The curve  $C$  is illustrated in Figure 5.5 and is defined by the explicit function  $y = x^3$ . Hence we can use  $x$  as the parameter. Using the differential  $dy = 3x^2 dx$ , we apply (9) and (10):

$$\begin{aligned} \int_C xy dx + x^2 dy &= \int_{-1}^2 x(x^3) dx + x^2(3x^2 dx) \\ &= \int_{-1}^2 4x^4 dx = \left. \frac{4}{5} x^5 \right|_{-1}^2 = \frac{132}{5}. \end{aligned}$$

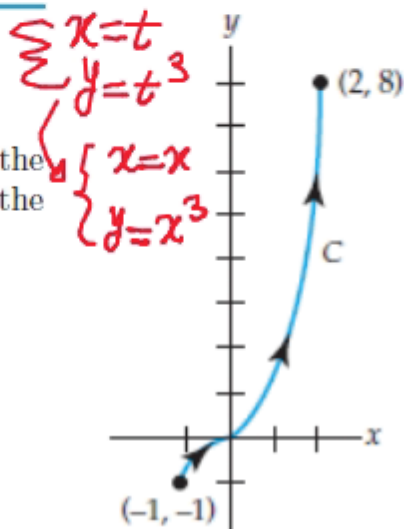

### Orientation of a Curve

In definite integration we normally assume that the interval of integration is  $a \leq x \leq b$  and the symbol  $\int_a^b f(x) dx$  indicates that we are integrating in the positive direction on the  $x$ -axis. Integration in the opposite direction, from  $x = b$  to  $x = a$ , results in the negative of the original integral:

$$\int_b^a f(x) dx = - \int_a^b f(x) dx.$$

*definition*  
*Calculus*

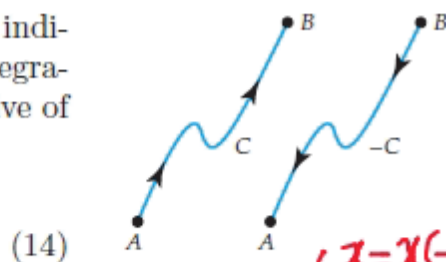

## Complex Integrals

### Curves Revisited

Suppose the continuous real-valued functions  $x = x(t)$ ,  $y = y(t)$ ,  $a \leq t \leq b$ , are parametric equations of a curve  $C$  in the complex plane. If we use these equations as the real and imaginary parts in  $z = x + iy$ , we saw in Section 2.2 that we can describe the points  $z$  on  $C$  by means of a complex-valued function of a real variable  $t$  called a **parametrization** of  $C$ :

$$z(t) = x(t) + iy(t), \quad a \leq t \leq b.$$

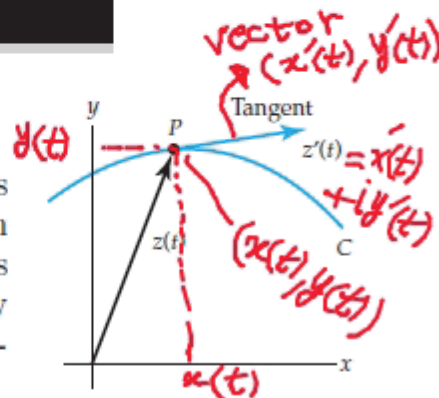

(1) Figure 5.16  $z'(t) = x'(t) + iy'(t)$  tangent vector

## Steps Leading to the Definition of the Complex Integral

1. Let  $f$  be a function of a complex variable  $z$  defined at all points on a smooth curve  $C$  that lies in some region of the complex plane. Let  $C$  be defined by the parametrization  $z(t) = x(t) + iy(t)$ ,  $a \leq t \leq b$ .
2. Let  $P$  be a partition of the parameter interval  $[a, b]$  into  $n$  subintervals  $[t_{k-1}, t_k]$  of length  $\Delta t_k = t_k - t_{k-1}$ :

$$a = t_0 < t_1 < t_2 < \dots < t_{n-1} < t_n = b.$$

The partition  $P$  induces a partition of the curve  $C$  into  $n$  subarcs whose initial and terminal points are the pairs of numbers

$$\begin{array}{ll} z_0 = x(t_0) + iy(t_0), & z_1 = x(t_1) + iy(t_1), \\ z_1 = x(t_1) + iy(t_1), & z_2 = x(t_2) + iy(t_2), \\ \vdots & \vdots \\ z_{n-1} = x(t_{n-1}) + iy(t_{n-1}), & z_n = x(t_n) + iy(t_n). \end{array}$$

Let  $\Delta z_k = z_k - z_{k-1}$ ,  $k = 1, 2, \dots, n$ . See Figure 5.19.

3. Let  $\|P\|$  be the norm of the partition  $P$  of  $[a, b]$ , that is, the length of the longest subinterval.
4. Choose a point  $z_k^* = x_k^* + iy_k^*$  on each subarc of  $C$ . See Figure 5.19.
5. Form  $n$  products  $f(z_k^*)\Delta z_k$ ,  $k = 1, 2, \dots, n$ , and then sum these products:

$$\sum_{k=1}^n f(z_k^*)\Delta z_k.$$

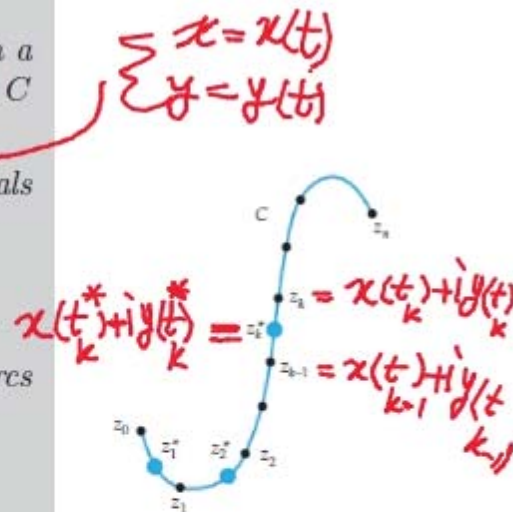

Figure 5.19 Partition of curve  $C$  into  $n$  subarcs is induced by a partition  $P$  of the parameter interval  $[a, b]$ .

### Definition 5.3 Complex Integral

The complex integral of  $f$  on  $C$  is

$$\int_C f(z) dz = \lim_{\|P\| \rightarrow 0} \sum_{k=1}^n f(z_k^*)\Delta z_k. \quad (2)$$

If the limit in (2) exists, then  $f$  is said to be **integrable** on  $C$ . The limit exists whenever if  $f$  is continuous at all points on  $C$  and  $C$  is either smooth or piecewise smooth. Consequently we shall, hereafter, assume these conditions as a matter of course. Moreover, we will use the notation  $\oint_C f(z) dz$  to represent a complex integral around a *positively oriented* closed curve  $C$ . When it is important to distinguish the direction of integration around a closed curve, we will employ the notations

$$\oint_C^+ f(z) dz \quad \text{and} \quad \oint_C^- f(z) dz$$

to denote integration in the positive and negative directions, respectively.



If  $f_1$  and  $f_2$  are real-valued functions of a real variable  $t$  continuous on a common interval  $a \leq t \leq b$ , then we define the integral of the complex-valued function  $f(t) = f_1(t) + if_2(t)$  on  $a \leq t \leq b$  in terms of the definite integrals of the real and imaginary parts of  $f$ .

$$\int_a^b f(t) dt = \int_a^b f_1(t) dt + i \int_a^b f_2(t) dt. \quad (4)$$

The continuity of  $f_1$  and  $f_2$  on  $[a, b]$  guarantees that both  $\int_a^b f_1(t) dt$  and  $\int_a^b f_2(t) dt$  exist.

### Evaluation of Contour Integrals

To facilitate the discussion on how to evaluate a contour integral  $\int_C f(z) dz$ , let us write (2) in an abbreviated form. If we use  $u + iv$  for  $f$ ,  $\Delta x + i\Delta y$  for  $\Delta z$ ,  $\lim_{\|P\| \rightarrow 0}$  for  $\lim_{n \rightarrow \infty}$ ,  $\sum$  for  $\sum_{k=1}^n$  and then suppress all subscripts, (2) becomes

$$\int_C f(z) dz = \lim \sum (u + iv)(\Delta x + i\Delta y) = \lim \left[ \sum (u\Delta x - v\Delta y) + i \sum (v\Delta x + u\Delta y) \right].$$

The interpretation of the last line is

$$\int_C f(z) dz = \int_C u dx - v dy + i \int_C v dx + u dy. \quad (9)$$

See Definition 5.2. In other words, the real and imaginary parts of a contour integral  $\int_C f(z) dz$  are a pair of real line integrals  $\int_C u dx - v dy$  and  $\int_C v dx + u dy$ . Now if  $x = x(t)$ ,  $y = y(t)$ ,  $a \leq t \leq b$  are parametric equations of  $C$ , then  $dx = x'(t) dt$ ,  $dy = y'(t) dt$ . By replacing the symbols  $x$ ,  $y$ ,  $dx$ , and  $dy$  by  $x(t)$ ,  $y(t)$ ,  $x'(t) dt$ , and  $y'(t) dt$ , respectively, the right side of (9) becomes

$$\int_a^b [u(x(t), y(t)) x'(t) - v(x(t), y(t)) y'(t)] dt + i \int_a^b [v(x(t), y(t)) x'(t) + u(x(t), y(t)) y'(t)] dt. \quad (10)$$

If we use the complex-valued function (1) to describe the contour  $C$ , then (10) is the same as  $\int_a^b f(z(t)) z'(t) dt$  when the integrand

$$f(z(t)) z'(t) = [u(x(t), y(t)) + iv(x(t), y(t))] [x'(t) + iy'(t)] \Rightarrow \int_C f(z) dz = \int_a^b f(z(t)) z'(t) dt.$$

is multiplied out and  $\int_a^b f(z(t)) z'(t) dt$  is expressed in terms of its real and imaginary parts. Thus we arrive at a practical means of evaluating a contour integral.

### EXAMPLE 1 Evaluating a Contour Integral

Evaluate  $\int_C \bar{z} dz$ , where  $C$  is given by  $x = 3t$ ,  $y = t^2$ ,  $-1 \leq t \leq 4$ .

**Solution** From (1) a parametrization of the contour  $C$  is  $z(t) = 3t + it^2$ . Therefore, with the identification  $f(z) = \bar{z}$  we have  $f(z(t)) = \overline{3t + it^2} = 3t - it^2$ . Also,  $z'(t) = 3 + 2it$ , and so by (11) the integral is

$$\begin{aligned} \int_C \bar{z} dz &= \int_{-1}^4 (3t - it^2)(3 + 2it) dt = \int_{-1}^4 [2t^3 + 9t + 3t^2i] dt. \\ &= \int_{-1}^4 (2t^3 + 9t) dt + i \int_{-1}^4 3t^2 dt \\ &= \left( \frac{1}{2}t^4 + \frac{9}{2}t^2 \right) \Big|_{-1}^4 + it^3 \Big|_{-1}^4 = 195 + 65i. \end{aligned}$$

u+iv = ∫u + i∫v

### EXAMPLE 3 C Is a Piecewise Smooth Curve

Evaluate  $\int_C (x^2 + iy^2) dz$ , where  $C$  is the contour shown in Figure 5.20.

**Solution** In view of Theorem 5.2(iii) we write

$$\begin{aligned} \int_C (x^2 + iy^2) dz &= \int_{C_1} (x^2 + iy^2) dz + \int_{C_2} (x^2 + iy^2) dz. \\ &= \int_0^1 (t^2 + it^2)(1+i) dt + \dots \end{aligned}$$

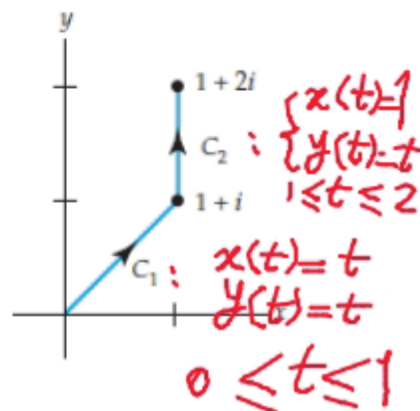

### Theorem 5.3 A Bounding Theorem

If  $f$  is continuous on a smooth curve  $C$  and if  $|f(z)| \leq M$  for all  $z$  on  $C$ , then  $|\int_C f(z) dz| \leq ML$ , where  $L$  is the length of  $C$ .

**Proof** It follows from the form of the triangle inequality given in (11) of Section 1.2 that

$$\left| \sum_{k=1}^n f(z_k^*) \Delta z_k \right| \leq \sum_{k=1}^n |f(z_k^*)| |\Delta z_k| \leq M \sum_{k=1}^n |\Delta z_k| \approx L \quad (14)$$

Because  $|\Delta z_k| = \sqrt{(\Delta x_k)^2 + (\Delta y_k)^2}$ , we can interpret  $|\Delta z_k|$  as the length of the chord joining the points  $z_k$  and  $z_{k-1}$  on  $C$ . Moreover, since the sum of the lengths of the chords cannot be greater than the length  $L$  of  $C$ , the inequality (14) continues as  $|\sum_{k=1}^n f(z_k^*) \Delta z_k| \leq ML$ . Finally, the continuity of  $f$  guarantees that  $\int_C f(z) dz$  exists, and so if we let  $\|P\| \rightarrow 0$ , the last inequality yields  $|\int_C f(z) dz| \leq ML$ .

∫<sub>C</sub> f(z) dz = lim [∑ f(z\_k^\*) Δz\_k] as ||P|| → 0



Proof:  $|\int_C f(z) dz| = \left| \int_a^b f(z(t)) z'(t) dt \right| \leq \int_a^b |f(z(t))| |z'(t)| dt \leq M \int_a^b \sqrt{x'(t)^2 + y'(t)^2} dt$

### EXAMPLE 4 A Bound for a Contour Integral

Find an upper bound for the absolute value of  $\oint_C \frac{e^z}{z+1} dz$  where  $C$  is the circle  $|z| = 4$ .

$$\oint_C \frac{e^z}{z+1} dz$$

$f(z)$

**Solution** First, the length  $L$  (circumference) of the circle of radius 4 is  $8\pi$ . Next, from the inequality (7) of Section 1.2, it follows for all points  $z$  on the circle that  $|z+1| \geq |z| - 1 = 4 - 1 = 3$ . Thus

$$\left| \frac{e^z}{z+1} \right| \leq \frac{|e^z|}{|z+1|} = \frac{|e^x|}{|z+1|} \leq \frac{e^x}{3} \quad (15)$$

$|z+1| \geq |z| - 1 = 4 - 1 = 3$

In addition,  $|e^z| = |e^x(\cos y + i \sin y)| = e^x$ . For points on the circle  $|z| = 4$ , the maximum that  $x = \operatorname{Re}(z)$  can be is 4, and so (15) yields

$$\left| \frac{e^z}{z+1} \right| \leq \frac{e^4}{3}$$

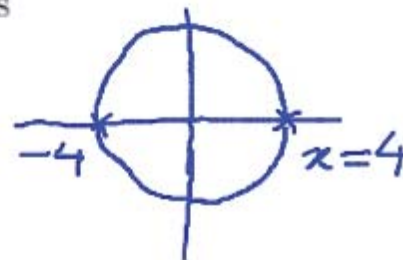

From the  $ML$ -inequality (Theorem 5.3) we have

$$\left| \oint_C \frac{e^z}{z+1} dz \right| \leq \frac{8\pi e^4}{3} M$$

### Remarks

There is no unique parametrization for a contour  $C$ . You should verify that

$$z(t) = e^{it} = \cos t + i \sin t, \quad 0 \leq t \leq 2\pi$$

$$z(t) = e^{i2\pi t} = \cos 2\pi t + i \sin 2\pi t, \quad 0 \leq t \leq 1$$

$$z(t) = e^{i\pi t/2} = \cos \frac{\pi t}{2} + i \sin \frac{\pi t}{2}, \quad 0 \leq t \leq 4$$

$$\begin{aligned} \circ \sqrt{t} &= 2\pi \sqrt{2\pi} \\ \circ \sqrt{t} &\leq 1 \end{aligned}$$

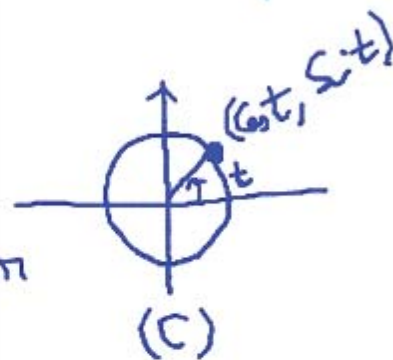

are all parametrizations, oriented in the positive direction, for the unit circle  $|z| = 1$ .

## Simply and Multiply Connected Domains

Recall from Section 1.5 that a domain is an open connected set in the complex plane. We say that a domain  $D$  is **simply connected** if every simple closed contour  $C$  lying entirely in  $D$  can be shrunk to a point without leaving  $D$ . See Figure 5.26. In other words, if we draw any simple closed contour  $C$  so that it lies entirely within a simply connected domain, then  $C$  encloses only points of the domain  $D$ . Expressed yet another way, a simply connected domain has no “holes” in it. The entire complex plane is an example of a simply connected domain; the annulus defined by  $1 < |z| < 2$  is not simply connected. (Why?) A domain that is not simply connected is called a **multiply connected domain**; that is, a multiply connected domain has “holes” in it. Note in Figure 5.27 that if the curve  $C_2$  enclosing the “hole” were shrunk to a point, the curve would have to leave  $D$  eventually. We call a domain with one “hole” **doubly connected**, a domain with two “holes” **triply connected**, and so on. The open disk defined by  $|z| < 2$  is a simply connected domain; the open circular annulus defined by  $1 < |z| < 2$  is a doubly connected domain.

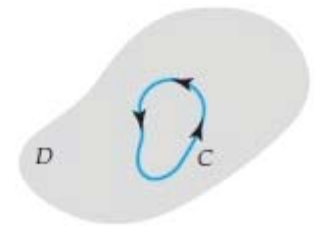

Figure 5.26 Simply connected domain  $D$

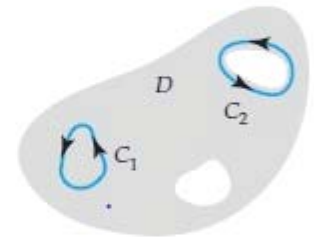

Figure 5.27 Multiply connected domain  $D$

## Cauchy's Theorem

In 1825 the French mathematician Louis-Augustin Cauchy proved one of the most important theorems in complex analysis.

### Cauchy's Theorem

Suppose that a function  $f$  is analytic in a simply connected domain  $D$  and that  $f'$  is continuous in  $D$ . Then for every simple closed contour  $C$  in  $D$ ,  $\oint_C f(z) dz = 0$ . (1)

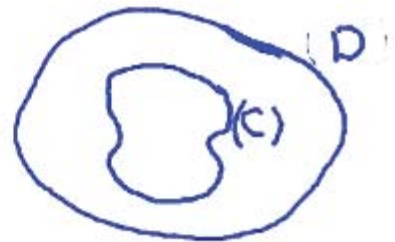

### Cauchy's Proof

*u+iv dx+idy*

$$\begin{aligned} \oint_C f(z) dz &= \oint_C u(x, y) dx - v(x, y) dy + i \oint_C v(x, y) dx + u(x, y) dy \\ &= \iint_D \left( -\frac{\partial v}{\partial x} - \frac{\partial u}{\partial y} \right) dA + i \iint_D \left( \frac{\partial u}{\partial x} - \frac{\partial v}{\partial y} \right) dA. \end{aligned}$$

$$\oint_C P dx + Q dy = \iint_D \left( \frac{\partial Q}{\partial x} - \frac{\partial P}{\partial y} \right) dA.$$

*$\oint_C f(z) dz = 0$  (C)*

$$\frac{\partial u}{\partial x} = \frac{\partial v}{\partial y} \text{ and } \frac{\partial u}{\partial y} = -\frac{\partial v}{\partial x}.$$

$$\begin{aligned} &= \iint_D \left( -\frac{\partial v}{\partial x} + \frac{\partial v}{\partial x} \right) dA + i \iint_D \left( \frac{\partial v}{\partial y} - \frac{\partial v}{\partial y} \right) dA \\ &= \iint_D (0) dA + i \iint_D (0) dA = 0. \quad \square \end{aligned}$$



### Theorem 5.4 Cauchy-Goursat Theorem

Suppose that a function  $f$  is analytic in a simply connected domain  $D$ . Then for every simple closed contour  $C$  in  $D$ ,  $\oint_C f(z) dz = 0$ .

Since the interior of a simple closed contour is a simply connected domain, the Cauchy-Goursat theorem can be stated in the slightly more practical manner:

If  $f$  is analytic at all points within and on a simple closed contour  $C$ , then  $\oint_C f(z) dz = 0$ . (4)

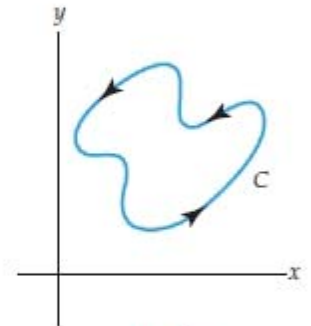

### EXAMPLE 2 Applying the Cauchy-Goursat Theorem

Evaluate  $\oint_C \frac{dz}{z^2}$ , where the contour  $C$  is the ellipse  $(x - 2)^2 + \frac{1}{4}(y - 5)^2 = 1$ .

**Solution** The rational function  $f(z) = 1/z^2$  is analytic everywhere except at  $z = 0$ . But  $z = 0$  is not a point interior to or on the simple closed elliptical contour  $C$ . Thus, from (4) we have that  $\oint_C \frac{dz}{z^2} = 0$ .



### Theorem 5.5 Cauchy-Goursat Theorem for Multiply Connected Domains

Suppose  $C, C_1, \dots, C_n$  are simple closed curves with a positive orientation such that  $C_1, C_2, \dots, C_n$  are interior to  $C$  but the regions interior to each  $C_k, k = 1, 2, \dots, n$ , have no points in common. If  $f$  is analytic on each contour and at each point interior to  $C$  but exterior to all the  $C_k, k = 1, 2, \dots, n$ , then

$$\oint_C f(z) dz = \sum_{k=1}^n \oint_{C_k} f(z) dz. \quad (8)$$

$$\oint_C f(z) dz = \oint_{C_1} f(z) dz.$$

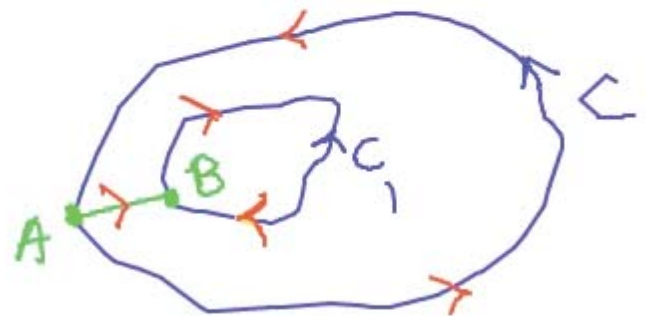

$\int_C f = 0$   
 $C + AB + BA + (-C_1)$   
 $\int_C f + \int_{AB} f + \int_{BA} f - \int_{C_1} f = 0 \Rightarrow \int_C f = -\int_{C_1} f = \int_{C_1} f \cdot \square$

**EXAMPLE**  $\otimes$  if  $z_0$  is any constant complex number interior to any simple closed contour  $C$ , then for  $n$  the circle  $|z - z_0| = r$

$$\oint_C \frac{dz}{(z - z_0)^n} = \begin{cases} 2\pi i & n = 1 \\ 0, & n \neq 1. \end{cases}$$

$$\oint_C \frac{dz}{(z - z_0)^n} = \int_0^{2\pi} \frac{i e^{it} dt}{(e^{it})^n} = i \int_0^{2\pi} (e^{it})^{1-n} dt = \begin{cases} i \int_0^{2\pi} 1 dt = 2\pi i & n = 1 \\ i \int_0^{2\pi} e^{it(1-n)} dt & n \neq 1 \end{cases}$$

analytic  $\stackrel{\text{(By the)}}{=} 0$  (C-G theorem)

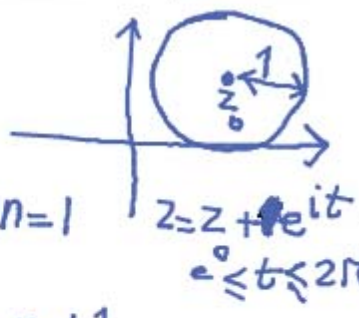

**EXAMPLE 4** Applying Formula (6)

Evaluate  $\oint_C \frac{5z + 7}{z^2 + 2z - 3} dz$ , where  $C$  is circle  $|z - 2| = 2$ .

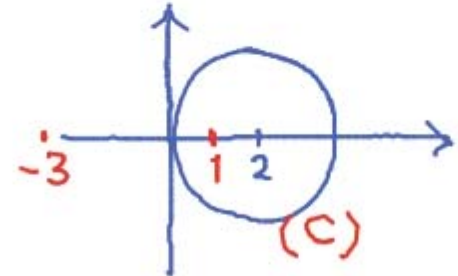

Solution

$$\frac{5z + 7}{z^2 + 2z - 3} = \frac{3}{z - 1} + \frac{2}{z + 3}$$

$$\oint_C \frac{5z + 7}{z^2 + 2z - 3} dz = 3 \oint_C \frac{1}{z - 1} dz + 2 \oint_C \frac{1}{z + 3} dz = 3(2\pi i) + 2(0) = 6\pi i.$$

(by example  $\otimes$ )  $\quad$   $\circ$  analytic (by the C-G theorem)

**Definition 5.4 Independence of the Path**

Let  $z_0$  and  $z_1$  be points in a domain  $D$ . A contour integral  $\int_C f(z) dz$  is said to be **independent of the path** if its value is the same for all contours  $C$  in  $D$  with initial point  $z_0$  and terminal point  $z_1$ .

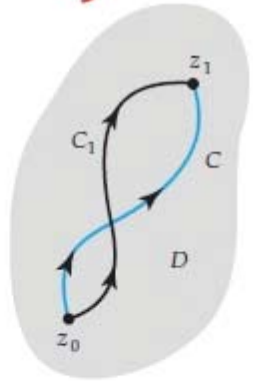

$$\int_C f(z) dz + \int_{-C_1} f(z) dz = 0. \quad \text{Thus } \int_C f(z) dz = \int_{C_1} f(z) dz$$

**Theorem 5.6 Analyticity Implies Path Independence**

Suppose that a function  $f$  is analytic in a simply connected domain  $D$  and  $C$  is any contour in  $D$ . Then  $\int_C f(z) dz$  is independent of the path  $C$ .

### EXAMPLE 1 Choosing a Different Path

Evaluate  $\int_C 2z dz$ , where  $C$  is the contour shown in color in Figure 5.39.

*entire function*

**Solution** Since the function  $f(z) = 2z$  is entire, we can, in view of Theorem 5.6, replace the piecewise smooth path  $C$  by any convenient contour  $C_1$  joining  $z_0 = -1$  and  $z_1 = -1 + i$ . Specifically, if we choose the contour  $C_1$  to be the vertical line segment  $x = -1, 0 \leq y \leq 1$ , shown in black in Figure 5.39, then  $z = -1 + iy, dz = idy$ . Therefore,

$$\int_C 2z dz = \int_{C_1} 2z dz = -2 \int_0^1 y dy - 2i \int_0^1 dy = -1 - 2i.$$

*$\int_a^b f(z(t)) z'(t) dt = \int_0^1 2(-1+ti)(i) dt$*

A contour integral  $\int_C f(z) dz$  that is independent of the path  $C$  is usually written  $\int_{z_0}^{z_1} f(z) dz$ , where  $z_0$  and  $z_1$  are the initial and terminal points of  $C$ .

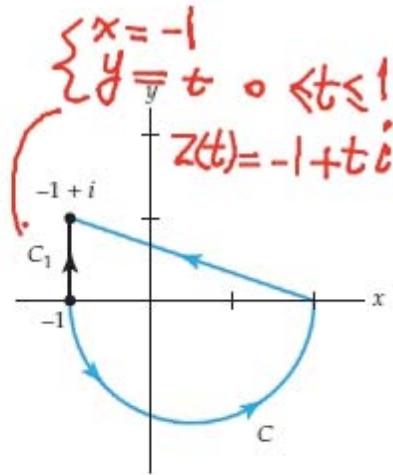

### Definition 5.5 Antiderivative

Suppose that a function  $f$  is continuous on a domain  $D$ . If there exists a function  $F$  such that  $F'(z) = f(z)$  for each  $z$  in  $D$ , then  $F$  is called an antiderivative of  $f$ .

*$f(x) = \begin{cases} 0 & x=0 \\ x^2 \sin \frac{1}{x} & x \neq 0 \end{cases}$*   
 *$f'(x) = \begin{cases} 0 & x=0 \\ 2x \sin \frac{1}{x} - \cos \frac{1}{x} & x \neq 0 \end{cases}$*   
*is not cts at 0.*

### Theorem 5.7 Fundamental Theorem for Contour Integrals

Suppose that a function  $f$  is continuous on a domain  $D$  and  $F$  is an antiderivative of  $f$  in  $D$ . Then for any contour  $C$  in  $D$  with initial point  $z_0$  and terminal point  $z_1$ ,

$$\int_C f(z) dz = F(z_1) - F(z_0). \quad (4)$$



**Proof**

$$\begin{aligned} \int_C f(z) dz &= \int_a^b f(z(t)) z'(t) dt = \int_a^b F'(z(t)) z'(t) dt \\ &= \int_a^b \frac{d}{dt} F(z(t)) dt \quad \leftarrow \text{chain rule} \\ &= F(z(t)) \Big|_a^b \\ &= F(z(b)) - F(z(a)) = F(z_1) - F(z_0). \end{aligned}$$

*f is cts*  
 ①  $F(x) = \int_a^x f(t) dt$  is cts &  $F'(x) = f(x)$   
 ②  $G$  is an antiderivative of  $f$ , then  $\int_a^b f(x) dx = G(b) - G(a)$   
**F.T.i.C**

### EXAMPLE 3 Applying Theorem 5.7

Evaluate  $\int_C \cos z \, dz$ , where  $C$  is any contour with initial point  $z_0 = 0$  and terminal point  $z_1 = 2 + i$ .

**Solution**  $F(z) = \sin z$  is an antiderivative of  $f(z) = \cos z$  since  $F'(z) = \cos z = f(z)$ . Therefore, from (4) we have

$$\int_C \cos z \, dz = \int_0^{2+i} \cos z \, dz = \sin z \Big|_0^{2+i} = \sin(2+i) - \sin 0 = \sin(2+i).$$

*entire*  
 $\cos z = \frac{e^{iz} + e^{-iz}}{2}$   
 $e^{iz} = \exp(iz)$  is entire.

**Some Conclusions** We can draw several immediate conclusions from Theorem 5.7. First, observe that if the contour  $C$  is closed, then  $z_0 = z_1$  and, consequently,

$$\oint_C f(z) \, dz = 0. \quad (5)$$

Next, since the value of  $\int_C f(z) \, dz$  depends only on the points  $z_0$  and  $z_1$ , this value is the same for any contour  $C$  in  $D$  connecting these points. In other words:

If a continuous function  $f$  has an antiderivative  $F$  in  $D$ , then  $\int_C f(z) \, dz$  is independent of the path.

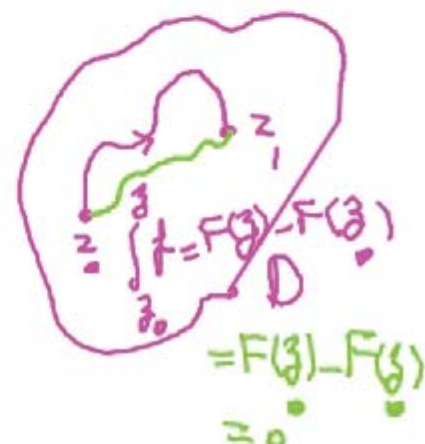

$$\int_C f(z) \, dz + \int_{-C} f(z) \, dz = 0 \Rightarrow \int_C f(z) \, dz = \int_{C_1} f(z) \, dz$$

### EXAMPLE 4 Using the Logarithmic Function

Evaluate  $\int_C \frac{1}{z} \, dz$ , where  $C$  is the contour shown in Figure 5.41.

**Solution** Suppose that  $D$  is the simply connected domain defined by  $x > 0$ ,  $y > 0$ , in other words,  $D$  is the first quadrant in the  $z$ -plane. In this case,  $\text{Ln } z$  is an antiderivative of  $1/z$  since both these functions are analytic in  $D$ . Hence by (4),

$$\int_3^{2i} \frac{1}{z} \, dz = \text{Ln } z \Big|_3^{2i} = \text{Ln}(2i) - \text{Ln } 3.$$

From (14) of Section 4.1,

$$\text{Ln } 2i = \log_e 2 + \frac{\pi}{2}i \quad \text{and} \quad \text{Ln } 3 = \log_e 3$$

*0 + 2i*      *3 + 0i*

$$\langle \text{Ln } z \rangle' = \frac{1}{z}$$

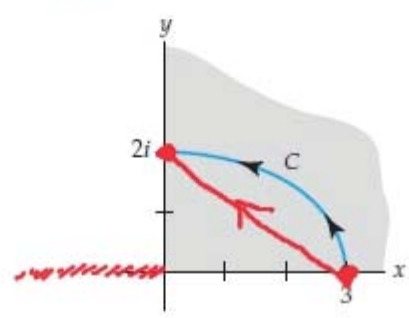

If  $f$  is continuous and  $\int_C f(z) dz$  is independent of the path  $C$  in a domain  $D$ , then  $f$  has an antiderivative everywhere in  $D$ . (7)

The last statement is important and deserves a proof.

**Proof of (7)** Assume  $f$  is continuous and  $\int_C f(z) dz$  is independent of the path in a domain  $D$  and that  $F$  is a function defined by  $F(z) = \int_{z_0}^z f(s) ds$ , where  $s$  denotes a complex variable,  $z_0$  is a fixed point in  $D$ , and  $z$  represents any point in  $D$ . We wish to show that  $F'(z) = f(z)$ , that is,

$$F(z) = \int_{z_0}^z f(s) ds \quad (8)$$

*Handwritten:  $\int_{z_0}^z f(s) ds$*

is an antiderivative of  $f$  in  $D$ . Now,

$$F(z + \Delta z) - F(z) = \int_{z_0}^{z+\Delta z} f(s) ds - \int_{z_0}^z f(s) ds = \int_z^{z+\Delta z} f(s) ds. \quad (9)$$

Because  $D$  is a domain, we can choose  $\Delta z$  so that  $z + \Delta z$  is in  $D$ . Moreover,  $z$  and  $z + \Delta z$  can be joined by a straight segment as shown in Figure 5.40. This is the contour we use in the last integral in (9). With  $z$  fixed, we can write

$$f(z)\Delta z = f(z) \int_z^{z+\Delta z} 1 ds = \int_z^{z+\Delta z} f(z) ds \Rightarrow f(z) = \frac{1}{\Delta z} \int_z^{z+\Delta z} f(z) ds. \quad (10)$$

*Handwritten:  $\int_z^{z+\Delta z} 1 ds = (z+\Delta z) - z = \Delta z$*

From (9) and the last result in (10) we have

$$\frac{F(z + \Delta z) - F(z)}{\Delta z} - f(z) = \frac{1}{\Delta z} \int_z^{z+\Delta z} [f(s) - f(z)] ds.$$

Now  $f$  is continuous at the point  $z$ . This means for any  $\varepsilon > 0$  there exists a  $\delta > 0$  so that  $|f(s) - f(z)| < \varepsilon$  whenever  $|s - z| < \delta$ . Consequently, if we choose  $\Delta z$  so that  $|\Delta z| < \delta$ , it follows from the  $ML$ -inequality of Section 5.2 that

$$\left| \frac{F(z + \Delta z) - F(z)}{\Delta z} - f(z) \right| = \left| \frac{1}{\Delta z} \int_z^{z+\Delta z} [f(s) - f(z)] ds \right| \leq \left| \frac{1}{\Delta z} \right| \varepsilon |\Delta z| = \varepsilon.$$

*Handwritten:  $\frac{1}{|\Delta z|} L M$  the length of the segment. an upper bound for  $|f(s) - f(z)|$  on the segment.*

Hence, we have shown that

$$\lim_{\Delta z \rightarrow 0} \frac{F(z + \Delta z) - F(z)}{\Delta z} = f(z) \quad \text{or} \quad F'(z) = f(z).$$

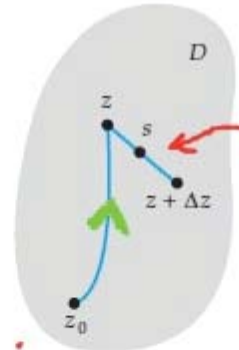
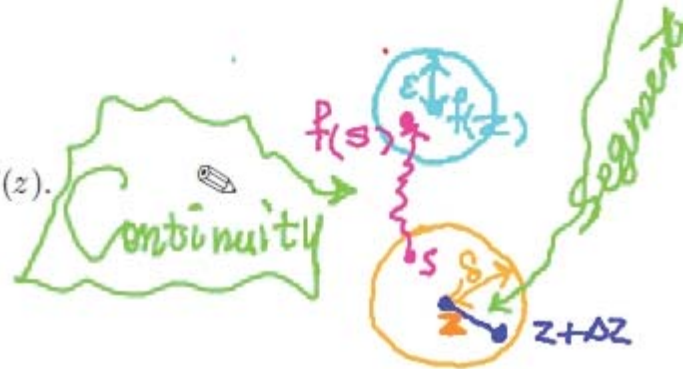

# 5.5 Cauchy's Integral Formulas and Their Consequences

## Theorem 5.9 Cauchy's Integral Formula

Suppose that  $f$  is analytic in a simply connected domain  $D$  and  $C$  is any simple closed contour lying entirely within  $D$ . Then for any point  $z_0$  within  $C$ ,

$$f(z_0) = \frac{1}{2\pi i} \oint_C \frac{f(z)}{z - z_0} dz. \quad (1)$$

**Proof** Let  $D$  be a simply connected domain,  $C$  a simple closed contour in  $D$ , and  $z_0$  an interior point of  $C$ . In addition, let  $C_1$  be a circle centered at  $z_0$  with radius small enough so that  $C_1$  lies within the interior of  $C$ . By the principle of deformation of contours, (5) of Section 5.3, we can write

$$\oint_C \frac{f(z)}{z - z_0} dz = \oint_{C_1} \frac{f(z)}{z - z_0} dz. \quad (2)$$

We wish to show that the value of the integral on the right is  $2\pi i f(z_0)$ . To this end we add and subtract the constant  $f(z_0)$  in the numerator of the integrand,

$$\begin{aligned} \oint_{C_1} \frac{f(z)}{z - z_0} dz &= \oint_{C_1} \frac{f(z_0) - f(z_0) + f(z)}{z - z_0} dz \\ &= f(z_0) \oint_{C_1} \frac{1}{z - z_0} dz + \oint_{C_1} \frac{f(z) - f(z_0)}{z - z_0} dz. \end{aligned} \quad (3)$$

From (6) of Section 5.3 we know that

$$\oint_{C_1} \frac{1}{z - z_0} dz = 2\pi i \quad (4)$$

and so (3) becomes

$$\oint_{C_1} \frac{f(z)}{z - z_0} dz = 2\pi i f(z_0) + \oint_{C_1} \frac{f(z) - f(z_0)}{z - z_0} dz. \quad (5)$$

Since  $f$  is continuous at  $z_0$ , we know that for any arbitrarily small  $\varepsilon > 0$  there exists a  $\delta > 0$  such that  $|f(z) - f(z_0)| < \varepsilon$  whenever  $|z - z_0| < \delta$ . In particular, if we choose the circle  $C_1$  to be  $|z - z_0| = \frac{1}{2}\delta < \delta$ , then by the *ML-inequality* (Theorem 5.3) the absolute value of the integral on the right side of the equality in (5) satisfies

$$\left| \oint_{C_1} \frac{f(z) - f(z_0)}{z - z_0} dz \right| \leq \frac{\varepsilon}{\delta/2} 2\pi \left( \frac{\delta}{2} \right) = 2\pi\varepsilon.$$

In other words, the absolute value of the integral can be made arbitrarily small by taking the radius of the circle  $C_1$  to be sufficiently small. This can happen only if the integral is 0. Thus (5) is  $\oint_{C_1} \frac{f(z)}{z - z_0} dz = 2\pi i f(z_0)$ . The theorem is proved by dividing both sides of the last result by  $2\pi i$ .

$f(z) = 1$

$1 = \frac{1}{2\pi i} \oint_C \frac{f(z)}{z - z_0} dz$

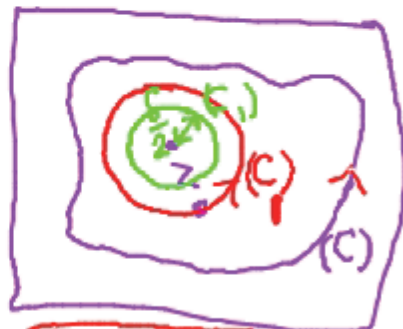

Given  $\omega \in \mathbb{C}$   
 $\exists \forall \varepsilon > 0: |\omega| < \varepsilon$   
 $\omega = 0$

Proof. If  $\omega \neq 0$ ,  
 by choosing  $\varepsilon = \frac{|\omega|}{2}$ ,  
 we get  $|\omega| < \frac{|\omega|}{2}$ , so  
 $1 < \frac{1}{2}$  which is impossible.  $\square$

OK claim

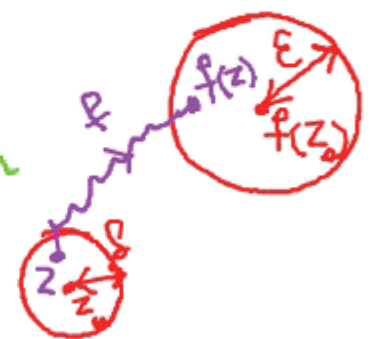

$\frac{|f(z) - f(z_0)|}{|z - z_0|} = \frac{|f(z) - f(z_0)|}{|z - z_0|}$   
 $\frac{\varepsilon}{\delta/2}$

### EXAMPLE 1 Using Cauchy's Integral Formula

Evaluate  $\oint_C \frac{z^2 - 4z + 4}{z + i} dz$ , where  $C$  is the circle  $|z| = 2$ .

**Solution** First, we identify  $f(z) = z^2 - 4z + 4$  and  $z_0 = -i$  as a point within the circle  $C$ . Next, we observe that  $f$  is analytic at all points within and on the contour  $C$ . Thus, by the Cauchy integral formula (1) we obtain

$$\oint_C \frac{z^2 - 4z + 4}{z + i} dz = 2\pi i f(-i) = 2\pi i(3 + 4i) = \pi(-8 + 6i).$$

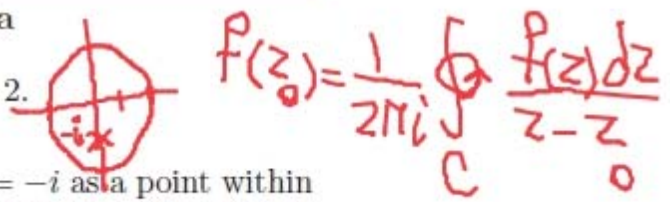

### Second Formula

We shall now build on Theorem 5.9 by using it to prove that the values of the derivatives  $f^{(n)}(z_0)$ ,  $n = 1, 2, 3, \dots$  of an analytic function are also given by a integral formula. This second integral formula is similar to (1) and is known by the name Cauchy's integral formula for derivatives.

### Theorem 5.10 Cauchy's Integral Formula for Derivatives

Suppose that  $f$  is analytic in a simply connected domain  $D$  and  $C$  is any simple closed contour lying entirely within  $D$ . Then for any point  $z_0$  within  $C$ ,

$$f^{(n)}(z_0) = \frac{n!}{2\pi i} \oint_C \frac{f(z)}{(z - z_0)^{n+1}} dz. \quad (6)$$

$$f^{(0)} = f \\ 0! = 1$$

### EXAMPLE 3 Using Cauchy's Integral Formula for Derivatives

Evaluate  $\oint_C \frac{z + 1}{z^4 + 2iz^3} dz$ , where  $C$  is the circle  $|z| = 1$ .

**Solution** Inspection of the integrand shows that it is not analytic at  $z = 0$  and  $z = -2i$ , but only  $z = 0$  lies within the closed contour. By writing the integrand as

$$\frac{z + 1}{z^4 + 2iz^3} = \frac{z + 1}{z^3(z + 2i)} f(z)$$

we can identify,  $z_0 = 0$ ,  $n = 2$ , and  $f(z) = (z + 1)/(z + 2i)$ . The quotient rule gives  $f''(z) = (2 - 4i)/(z + 2i)^3$  and so  $f''(0) = (2i - 1)/4i$ . Hence from (6) we find

$$\oint_C \frac{z + 1}{z^4 + 4z^3} dz = \frac{2\pi i}{2!} f''(0) = -\frac{\pi}{4} + \frac{\pi}{2}i.$$

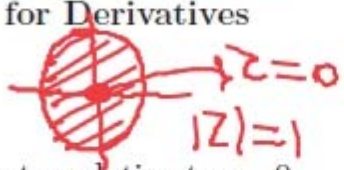

$$\oint_C \frac{f(z)}{(z - z_0)^{2+1}} dz = \frac{2\pi i f''(0)}{2!} \\ = \frac{2\pi i (2i - 1)}{4i}$$

**EXAMPLE 4** Using Cauchy's Integral Formula for Derivatives

Evaluate  $\int_C \frac{z^3 + 3}{z(z-i)^2} dz$ , where  $C$  is the figure-eight contour shown in Figure 5.45.

**Solution** Although  $C$  is not a simple closed contour, we can think of it as the union of two simple closed contours  $C_1$  and  $C_2$  as indicated in Figure 5.45. Since the arrows on  $C_1$  flow clockwise or in the negative direction, the opposite curve  $-C_1$  has positive orientation. Hence, we write

$$\begin{aligned} \int_C \frac{z^3 + 3}{z(z-i)^2} dz &= \int_{C_1} \frac{z^3 + 3}{z(z-i)^2} dz + \int_{C_2} \frac{z^3 + 3}{z(z-i)^2} dz \\ &= -\oint_{-C_1} \frac{\frac{z^3 + 3}{(z-i)^2}}{z} dz + \oint_{C_2} \frac{\frac{z^3 + 3}{z}}{(z-i)^2} dz = -I_1 + I_2, \end{aligned}$$

and we are in a position to use both formulas (1) and (6).

To evaluate  $I_1$  we identify  $z_0 = 0$ ,  $f(z) = (z^3 + 3)/(z-i)^2$ , and  $f(0) = -3$ . By (1) it follows that

$$I_1 = \oint_{-C_1} \frac{\frac{z^3 + 3}{(z-i)^2}}{z} dz = 2\pi i f(0) = 2\pi i(-3) = -6\pi i.$$

To evaluate  $I_2$  we now identify  $z_0 = i$ ,  $n = 1$ ,  $f(z) = (z^3 + 3)/z$ ,  $f'(z) = (2z^3 - 3)/z^2$ , and  $f'(i) = 3 + 2i$ . From (6) we obtain

$$I_2 = \oint_{C_2} \frac{\frac{z^3 + 3}{z}}{(z-i)^2} dz = \frac{2\pi i}{1!} f'(i) = 2\pi i(3 + 2i) = -4\pi + 6\pi i.$$

Finally, we get

$$\int_C \frac{z^3 + 3}{z(z-i)^2} dz = -I_1 + I_2 = 6\pi i + (-4\pi + 6\pi i) = -4\pi + 12\pi i.$$

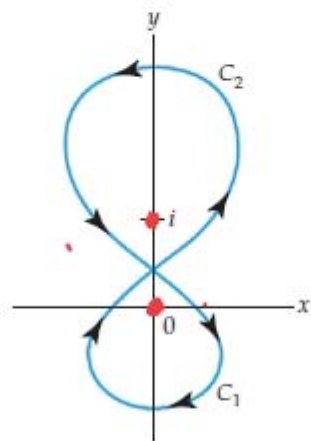

Figure 5.45 Contour for Example 4



### Theorem 5.11 Derivative of an Analytic Function Is Analytic

Suppose that  $f$  is analytic in a simply connected domain  $D$ . Then  $f$  possesses derivatives of all orders at every point  $z$  in  $D$ . The derivatives  $f', f'', f''', \dots$  are analytic functions in  $D$ .

If a function  $f(z) = u(x, y) + iv(x, y)$  is analytic in a simply connected domain  $D$ , we have just seen its derivatives of all orders exist at any point  $z$  in  $D$  and so  $f', f'', f''', \dots$  are continuous. From

$$f'(z) = \frac{\partial u}{\partial x} + i \frac{\partial v}{\partial x} = \frac{\partial v}{\partial y} - i \frac{\partial u}{\partial y}$$

$$f''(z) = \frac{\partial^2 u}{\partial x^2} + i \frac{\partial^2 v}{\partial x^2} = \frac{\partial^2 v}{\partial y \partial x} - i \frac{\partial^2 u}{\partial y \partial x}$$

$f' = u_1 + iv_1$   
 $f''(z) = \frac{\partial u_1}{\partial x} + i \frac{\partial v_1}{\partial x}$

we can also conclude that the real functions  $u$  and  $v$  have continuous partial derivatives of all orders at a point of analyticity.

**Cauchy's Inequality** We begin with an inequality derived from the Cauchy integral formula for derivatives.

### Theorem 5.12 Cauchy's Inequality

Suppose that  $f$  is analytic in a simply connected domain  $D$  and  $C$  is a circle defined by  $|z - z_0| = r$  that lies entirely in  $D$ . If  $|f(z)| \leq M$  for all points  $z$  on  $C$ , then

$$|f^{(n)}(z_0)| \leq \frac{n!M}{r^n}. \quad (7)$$

**Proof** From the hypothesis,

$$\left| \frac{f(z)}{(z - z_0)^{n+1}} \right| = \frac{|f(z)|}{r^{n+1}} \leq \frac{M}{r^{n+1}}.$$

Thus from (6) and the *ML*-inequality (Theorem 5.3), we have

$$|f^{(n)}(z_0)| = \frac{n!}{2\pi} \left| \oint_C \frac{f(z)}{(z - z_0)^{n+1}} dz \right| \leq \frac{n!}{2\pi} \frac{M}{r^{n+1}} 2\pi r = \frac{n!M}{r^n}.$$

$\frac{n!}{2\pi} ML \leq$

The number  $M$  in Theorem 5.12 depends on the circle  $|z - z_0| = r$ . But notice in (7) that if  $n = 0$ , then  $M \geq |f(z_0)|$  for any circle  $C$  centered at  $z_0$  as long as  $C$  lies within  $D$ . In other words, an upper bound  $M$  of  $|f(z)|$  on  $C$  cannot be smaller than  $|f(z_0)|$ .

$f$  is cts  
 on the compact set  $C$   
 $\equiv$  bounded & closed  
  
 See it is bounded on  $C$ :  
 $\exists M \forall z \in C, |f(z)| \leq M$

$z$  is on  $C$   
 so  $|z - z_0| = r$

### Theorem 5.13 Liouville's Theorem

The only bounded entire functions are constants.

**Proof** Suppose  $f$  is an entire function and is bounded, that is,  $|f(z)| \leq M$  for all  $z$ . Then for any point  $z_0$ , (7) gives  $|f'(z_0)| \leq M/r$ . By making  $r$  arbitrarily large we can make  $|f'(z_0)|$  as small as we wish. This means  $f'(z_0) = 0$  for all points  $z_0$  in the complex plane. Hence, by Theorem 3.6(ii),  $f$  must be a constant.

$$\left\{ \begin{aligned} |f^{(n)}(z)| &\leq \frac{n! M}{r^n} \\ n=1 \end{aligned} \right.$$

$\leq |f'(z)| \leq \frac{M}{r}$   
 Constant functions in  $r$ , say  $p(r)$   
 as  $r \rightarrow \infty$   
 $\therefore f'(z) = 0$

**Fundamental Theorem of Algebra** Theorem 5.13 enables us to establish a result usually learned—but never proved—in elementary algebra.

### Theorem 5.14 Fundamental Theorem of Algebra

If  $p(z)$  is a nonconstant polynomial, then the equation  $p(z) = 0$  has at least one root.

**Proof** Let us suppose that the polynomial  $p(z) = a_n z^n + a_{n-1} z^{n-1} + \dots + a_1 z + a_0$ ,  $n > 0$ , is not 0 for any complex number  $z$ . This implies that the reciprocal of  $p$ ,  $f(z) = 1/p(z)$ , is an entire function. Now

$$|f(z)| = \frac{1}{|a_n z^n + a_{n-1} z^{n-1} + \dots + a_1 z + a_0|}$$

$$= \frac{1}{|z|^n |a_n + a_{n-1}/z + \dots + a_1/z^{n-1} + a_0/z^n|}$$

$\hookrightarrow |a_n| \neq 0$

$p(z) = 0 \Rightarrow \exists z_0$   
 $p(z_0) = 0$   
 $a_1 z - a_0 = 0 \Rightarrow z = \frac{a_0}{a_1}$   
 $a_2 z^2 + a_1 z + a_0 = 0 \Rightarrow z = \dots$   
 (b)

Thus, we see that  $|f(z)| \rightarrow 0$  as  $|z| \rightarrow \infty$ , and conclude that the function  $f$  must be bounded for finite  $z$ . It then follows from Liouville's theorem that  $f$  is a constant, and therefore  $p$  is a constant. But this is a contradiction to our underlying assumption that  $p$  was not a constant polynomial. We conclude that there must exist at least one number  $z$  for which  $p(z) = 0$ .

$|f(z)|$  is cts on  $|z| \leq M$ ,  
 cts  
 so  $|f|$  is bounded on  $\{z: |z| \leq M\} = A$ ;  
 $\exists K > 0 \forall z \in A; |f(z)| < K$   
 this set is bounded & closed containing all of its boundary points  
 ①, ②



$\lim_{|z| \rightarrow \infty} |f(z)| = 0$   
 $|z| > M \Rightarrow |f(z)| < \epsilon$   
 $\epsilon = 1 \Rightarrow \exists M, \forall z; |z| > M \Rightarrow |f(z)| < 1$   
 $\forall z \in \mathbb{C}; |f(z)| < \max\{K, 1\}$   
 $\forall z \in C-A; |f(z)| < 1$   
 ①

### Theorem 5.15 Morera's Theorem

If  $f$  is continuous in a simply connected domain  $D$  and if  $\oint_C f(z) dz = 0$  for every closed contour  $C$  in  $D$ , then  $f$  is analytic in  $D$ .



**Proof** By the hypotheses of continuity of  $f$  and  $\oint_C f(z) dz = 0$  for every closed contour  $C$  in  $D$ , we conclude that  $\int_C f(z) dz$  is independent of the path. In the proof of (7) of Section 5.4 we then saw that the function  $F$  defined by  $F(z) = \int_{z_0}^z f(s) ds$  (where  $s$  denotes a complex variable,  $z_0$  is a fixed point in  $D$ , and  $z$  represents any point in  $D$ ) is an antiderivative of  $f$ ; that is,  $F'(z) = f(z)$ . Hence,  $F$  is analytic in  $D$ . In addition,  $F'(z)$  is analytic in view of Theorem 5.11. Since  $f(z) = F'(z)$ , we see that  $f$  is analytic in  $D$ . 

### Theorem 5.16 Maximum Modulus Theorem

Suppose that  $f$  is analytic and nonconstant on a closed region  $R$  bounded by a simple closed curve  $C$ . Then the modulus  $|f(z)|$  attains its maximum on  $C$ .

$$|z|^2 = z \bar{z}$$

#### EXAMPLE 5 Maximum Modulus

Find the maximum modulus of  $f(z) = 2z + 5i$  on the closed circular region defined by  $|z| \leq 2$ .  $|z| = 2 (C)$

**Solution** From (2) of Section 1.2 we know that  $|z|^2 = z\bar{z}$ . By replacing the symbol  $z$  by  $2z + 5i$  we have

$$|2z + 5i|^2 = (2z + 5i)\overline{(2z + 5i)} = (2z + 5i)(2\bar{z} - 5i) = 4z\bar{z} - 10i(z - \bar{z}) + 25. \quad (8)$$

But from (6) of Section 1.1,  $\bar{z} - z = 2i \operatorname{Im}(z)$ , and so (8) is

$$|2z + 5i|^2 = 4z\bar{z} + 20 \operatorname{Im}(z) + 25 = 4 + 20 \operatorname{Im} z + 25 = 41 + 20 \operatorname{Im} z \quad (9)$$

Because  $f$  is a polynomial, it is analytic on the region defined by  $|z| \leq 2$ . By Theorem 5.16,  $\max_{|z| \leq 2} |2z + 5i|$  occurs on the boundary  $|z| = 2$ . Therefore, on  $|z| = 2$ , (9) yields

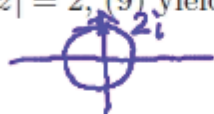

$$|2z + 5i| = \sqrt{41 + 20 \operatorname{Im}(z)}. \quad (10)$$

The last expression attains its maximum when  $\operatorname{Im}(z)$  attains its maximum on  $|z| = 2$ , namely, at the point  $z = 2i$ . Thus,  $\max_{|z| \leq 2} |2z + 5i| = \sqrt{81} = 9$ .



$f$  non-constant

If  $f(z) \neq 0$  then  $\frac{1}{f}$  is analytic. Using 5.16,  $|\frac{1}{f(z)}|$  attains its maximum on  $C$ , so  $|f(z)|$  attains its min on  $C$ .

25. If  $f$  is a polynomial function and  $C$  is a simple closed contour, then

$$\oint_C f(z) dz = 0$$

entire function



26.  $\int_C z \operatorname{Im}(z) dz = \underline{\hspace{2cm}}$ , where  $C$  is given by  $z(t) = 2t + t^2 i$ ,  $0 \leq t \leq 1$ .

$$\int_a^b f(z(t)) z'(t) dt = \int_0^1 (2t + t^2 i) (t^2) (2 + 2ti) dt = \int_0^1 u(t) dt + i \int_0^1 v(t) dt$$

$u(t) + i v(t)$

31.  $\int_C \frac{1}{z(z-1)} dz = \underline{\hspace{2cm}}$ , where  $C$  is  $|z-1| = \frac{1}{2}$ .



$$I = \oint_C \frac{f(z)}{z-1} dz = 2\pi i f(z_0) = 2\pi i f(1) = 2\pi i$$

35. If  $n$  is a positive integer and  $C$  is the contour  $|z| = 2$ , then

$$I = \oint_C z^{-n} e^z dz = \underline{\hspace{2cm}}$$

$$I = \oint_C \frac{e^z}{(z-0)^{n-1}} dz = \frac{2\pi i}{(n-1)!} f^{(n-1)}(0) = \frac{2\pi i}{(n-1)!} e^0$$

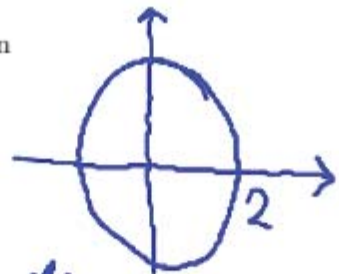

$$f(z) = e^z \Rightarrow f^{(k)}(z) = e^z \quad \forall k \geq 0$$

33. On the domain  $|z| > 0$ ,  $-\pi < \arg(z) < \pi$ , the derivative of the principal value of  $z^\alpha$  is  $\underline{\hspace{2cm}}$ .

$$z = e^{(\operatorname{Ln} z)^\alpha}$$

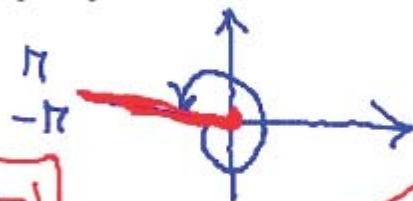

$$(z^\alpha)' = (\alpha \operatorname{Ln} z) e^{\alpha \operatorname{Ln} z} = \frac{\alpha}{z} z^\alpha = \alpha z^{\alpha-1}$$

$$z = (e^{\operatorname{Ln} z})^\alpha = e^{\alpha \operatorname{Ln} z}$$

$$\alpha = (e^{\operatorname{Ln} \alpha})^\alpha = e^{\alpha \operatorname{Ln} \alpha}$$

$$\int_C [f(z) + g(z)] dz = \int_C f(z) dz + \int_C g(z) dz$$

$$\int_a^b [f(z(t)) + g(z(t))] z'(t) dt = \int_a^b f(z(t)) z'(t) dt + \int_a^b g(z(t)) z'(t) dt$$

$\int_C f(z) dz = \int_{C_1} f(z) dz + \int_{C_2} f(z) dz$ , where  $C$  consists of the smooth curves  $C_1$  and  $C_2$  joined end to end.

$$\int_{C_1} f(z) dz + \int_{C_2} f(z) dz = \int_0^1 f(z(t)) z'(t) dt + \int_{1/2}^1 f(z(t)) z'(t) dt$$

formally  $\int_C f(z(t)) z'(t) dt = \int_C f(z) dz$

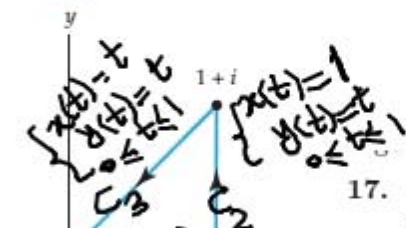

17.  $\int_C x dz$

Page 255

$\frac{\partial u}{\partial x} = 1 \neq 0 = \frac{\partial v}{\partial y}$ , so  $f(z) = x$  is not analytic.

$$\int_C x = \int_{C_1} x + \int_{C_2} x + \int_{C_3} x = \int_0^1 t dt + \int_0^1 1 dt + \int_0^1 t(1+i) dt = \dots$$

$\int_C (z^2 - z + 2) dz$  from  $i$  to  $1$  along the contour  $C$  given

$$\int_0^1 ((t+i(1-t^2))^2 - (t+i(1-t)i) + 2)(1-2t) dt$$

$z(t) = \begin{cases} x(t) = t \\ y(t) = 1-t^2 \end{cases}$   
 $0 \leq t \leq 1$

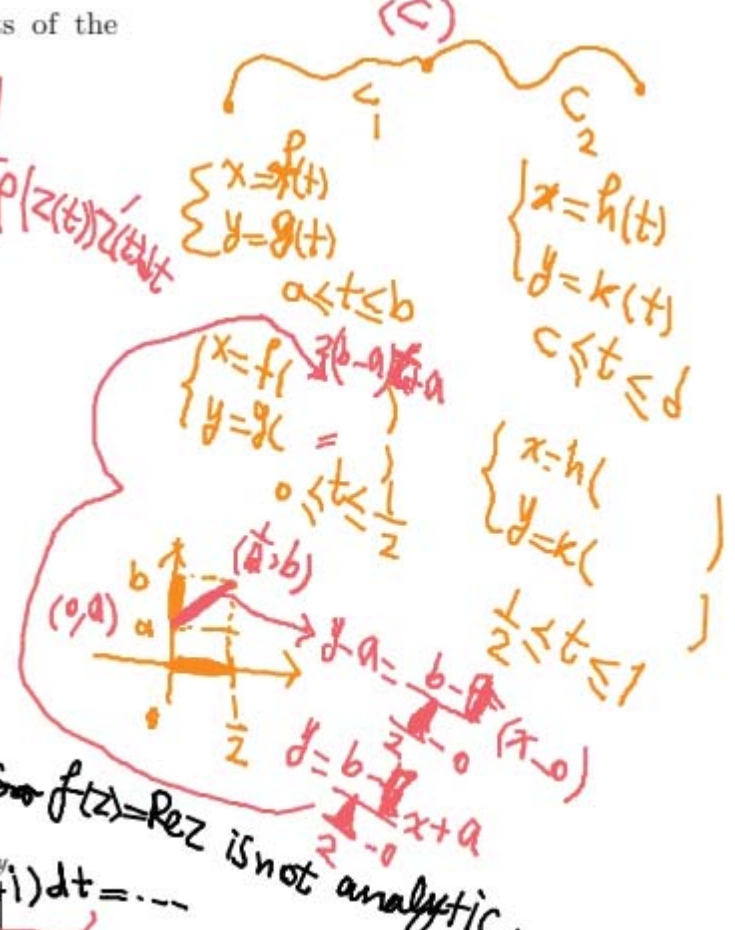

In Problems 25–28, find an upper bound for the absolute value of the given integral along the indicated contour.

25.  $\int_C \frac{e^z}{z^2 + 1} dz$ , where  $C$  is the circle  $|z| = 5$

26.  $\int_C \frac{1}{z^2 - 2i} dz$ , where  $C$  is the right half of the circle  $|z| = 6$  from  $z = -6i$  to  $z = 6i$

$$\left| \frac{e^z}{z^2 + 1} \right| = \frac{|e^z|}{|z^2 + 1|} \leq \frac{|e^x \cos y|}{|z^2| - 1} = \frac{e^x}{|z|^2 - 1} = \frac{e^x}{25 - 1} = \frac{e^x}{24} = \frac{e^5}{24}$$

$$\left| \frac{1}{z^2 - 2i} \right| \leq \frac{1}{|z^2| - |2i|} = \frac{1}{|z|^2 - 2} = \frac{1}{6^2 - 2} = \frac{1}{34}$$

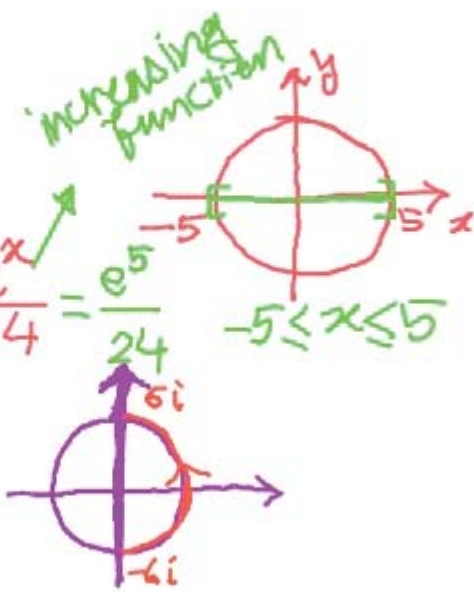

# Sequences

A sequence  $\{z_n\}$  is a function whose domain is the set of positive integers and whose range is a subset of the complex numbers  $\mathbb{C}$ . In other words, to each integer  $n = 1, 2, 3, \dots$  we assign a single complex number  $z_n$ . For example, the sequence  $\{1 + i^n\}$  is

$$\begin{array}{cccccc}
 1 + i, & 0, & 1 - i, & 2, & 1 + i, & \dots \\
 \uparrow & \uparrow & \uparrow & \uparrow & \uparrow & \\
 n = 1, & n = 2, & n = 3, & n = 4, & n = 5, & \dots
 \end{array} \tag{1}$$

$\forall \epsilon \in \mathbb{R}^+, \exists N \in \mathbb{N} \forall n \geq N : |z_n - L| < \epsilon$

If  $\lim z_n = L$ , we say the sequence  $\{z_n\}$  is **convergent**. In other words,  $\{z_n\}$  converges to the number  $L$  if for each positive real number  $\epsilon$  an  $N$  can be found such that  $|z_n - L| < \epsilon$  whenever  $n > N$ .

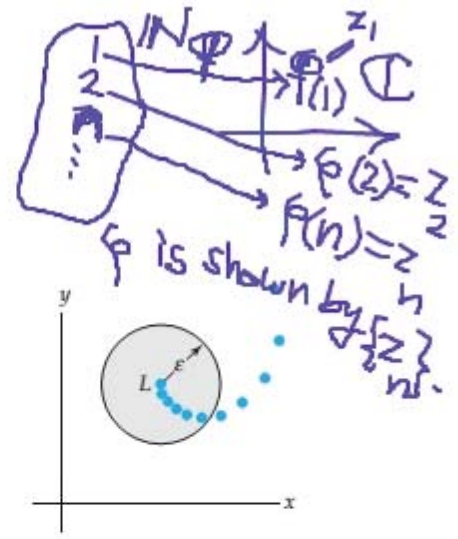

## EXAMPLE 1 A Convergent Sequence

The sequence  $\left\{ \frac{i^{n+1}}{n} \right\}$  converges since  $\lim_{n \rightarrow \infty} \frac{i^{n+1}}{n} = 0$ . As we see from

is not convergent  $\left\{ (-1)^n \right\}$   $\epsilon = 1 \rightarrow 1$  as  $k \rightarrow \infty$   
 $-1, -\frac{i}{2}, \frac{1}{3}, \frac{i}{4}, -\frac{1}{5}, \dots$   
 $\epsilon = 1 \rightarrow -1$  as  $k \rightarrow \infty$

and Figure 6.2, the terms of the sequence, marked by colored dots in the figure, spiral in toward the point  $z = 0$  as  $n$  increases.

$f(z) = e^z = \sum_{n=0}^{\infty} \frac{z^n}{n!}$   
 $f(z) = \sum_{n=0}^{\infty} \frac{z^n}{n!}$

$z_n \rightarrow L \iff z_{2k} \rightarrow L \ \& \ z_{2k-1} \rightarrow L \text{ as } k \rightarrow \infty$

$(\Rightarrow)$  Given  $\epsilon > 0$ ,  $\exists N \forall n \geq N : |z_n - L| < \epsilon$ . We observe that if  $k \geq \frac{N}{2}$  then  $2k \geq N$  and so  $|z_{2k} - L| < \epsilon$ . Hence  $\lim_{k \rightarrow \infty} z_{2k} = L$ . Similarly  $\lim_{k \rightarrow \infty} z_{2k-1} = L$ .

## Theorem 6.1 Criterion for Convergence

A sequence  $\{z_n\}$  converges to a complex number  $L = a + ib$  if and only if  $\text{Re}(z_n)$  converges to  $\text{Re}(L) = a$  and  $\text{Im}(z_n)$  converges to  $\text{Im}(L) = b$ .

$z_n = a_n + bi \rightarrow a + bi \iff a_n \rightarrow a \ \& \ b_n \rightarrow b$

Proof.  $(\Rightarrow)$

$|a_n - a| = |\text{Re}(z_n - L)| \leq |z_n - L|$

Given  $\epsilon > 0$ ,  $\exists N \forall n \geq N : |z_n - L| < \epsilon$ .

So  $|a_n - a| \leq |z_n - L| < \epsilon$

$\therefore \lim_{n \rightarrow \infty} a_n = a$ .  $\square$

$(\Leftarrow) |z_n - L| = |(a_n - a) + i(b_n - b)| \leq |a_n - a| + |b_n - b|$

$(\Leftarrow)$  Given  $\epsilon > 0$ , by the def of the limit

$\exists N_1 \forall k \geq N_1 : |z_{2k} - L| < \epsilon$   
 $\exists N_2 \forall k \geq N_2 : |z_{2k-1} - L| < \epsilon$

So by  $n = 2k \Rightarrow k = \frac{n}{2} > N_1 \Rightarrow n > 2N_1$   
 $n = 2k-1 \Rightarrow k = \frac{n+1}{2} > N_2 \Rightarrow n > 2N_2$   
 $|z_n - L| < \epsilon$

Choosing  $N = \max\{2N_1, 2N_2\}$ , we see that  $\forall n \geq N$

Case 1)  $n = 2k > N \Rightarrow k > \frac{N}{2} > N_1$   
 $\Rightarrow |z_{2k} - L| < \epsilon \Rightarrow |z_n - L| < \epsilon$

Case 2)  $n = 2k-1 \dots \therefore |z_n - L| < \epsilon$

**EXAMPLE 2** Illustrating Theorem 6.1

Consider the sequence  $\left\{ \frac{3 + ni}{n + 2ni} \right\}$ . From

$$z_n = \frac{3 + ni}{n + 2ni} = \frac{(3 + ni)(n - 2ni)}{n^2 + 4n^2} = \frac{2n^2 + 3n}{5n^2} + i \frac{n^2 - 6n}{5n^2},$$

we see that

$$\operatorname{Re}(z_n) = \frac{2n^2 + 3n}{5n^2} = \frac{2}{5} + \frac{3}{5n} \rightarrow \frac{2}{5}$$

and 
$$\operatorname{Im}(z_n) = \frac{n^2 - 6n}{5n^2} = \frac{1}{5} - \frac{6}{5n} \rightarrow \frac{1}{5}$$

as  $n \rightarrow \infty$ . From Theorem 6.1, the last results are sufficient for us to conclude that the given sequence converges to  $a + ib = \frac{2}{5} + \frac{1}{5}i$ . └

**Series** An **infinite series** or **series** of complex numbers

$$\sum_{k=1}^{\infty} z_k = z_1 + z_2 + z_3 + \cdots + z_n + \cdots$$

is **convergent** if the sequence of partial sums  $\{S_n\}$ , where

$$S_n = z_1 + z_2 + z_3 + \cdots + z_n$$

converges. If  $S_n \rightarrow L$  as  $n \rightarrow \infty$ , we say that the series converges to  $L$  or that the **sum** of the series is  $L$ .

**Geometric Series** A **geometric series** is any series of the form

$$\sum_{k=1}^{\infty} az^{k-1} = a + az + az^2 + \cdots + az^{n-1} + \cdots. \quad (2)$$

For (2), the  $n$ th term of the sequence of partial sums is

$$S_n = a + az + az^2 + \cdots + az^{n-1}. \quad (3)$$

$(1 - z)S_n = a(1 - z^n)$ . Solving the last equation for  $S_n$  gives us

$$S_n = \frac{a(1 - z^n)}{1 - z}. \quad (4)$$

Now  $z^n \rightarrow 0$  as  $n \rightarrow \infty$  whenever  $|z| < 1$ , and so  $S_n \rightarrow a/(1 - z)$ . In other words, for  $|z| < 1$  the sum of a geometric series (2) is  $a/(1 - z)$ :

$$\frac{a}{1 - z} = a + az + az^2 + \cdots + az^{n-1} + \cdots. \quad (5)$$

A geometric series (2) diverges when  $|z| \geq 1$ .

Handwritten notes in green ink:

$$\forall \epsilon > 0 \exists N \forall n \geq N; |z^{n+1} - 0| < \epsilon$$

$$|z|^{n+1} < \epsilon$$

$$(n+1) \ln(|z|) < \ln \epsilon$$

$$\rightarrow$$

$$n+1 > \frac{\ln \epsilon}{\ln |z|}$$

$$n > \frac{\ln \epsilon}{\ln |z|} - 1$$

## Theorem 6.2 A Necessary Condition for Convergence

If  $\sum_{k=1}^{\infty} z_k$  converges, then  $\lim_{n \rightarrow \infty} z_n = 0$ .

**Proof** Let  $L$  denote the sum of the series. Then  $S_n \rightarrow L$  and  $S_{n-1} \rightarrow L$  as  $n \rightarrow \infty$ . By taking the limit of both sides of  $S_n - S_{n-1} = z_n$  as  $n \rightarrow \infty$  we obtain the desired conclusion.

*Handwritten:*  $\lim_{n \rightarrow \infty} a_n = L \Rightarrow \lim_{n \rightarrow \infty} a_{n-1} = L$   $|a_{n-1} - L| < \epsilon$

*Handwritten:* Interview for PhD Entrance Exam

*Handwritten:* Given  $\epsilon > 0$ ,  $\exists N \in \mathbb{N}$  such that  $|a_n - L| < \epsilon$ . Choosing  $N_0 = N + 1$ . We see that  $n \geq N_0 \Rightarrow n-1 \geq N \Rightarrow |a_{n-1} - L| < \epsilon$ .

*Handwritten:* Th.  $\sum_{k=1}^{\infty} z_k$  conv.  $\Rightarrow \lim_{n \rightarrow \infty} z_n = 0$

## A Test for Divergence

The contrapositive\* of the proposition in Theorem 6.2 is the familiar  $n$ th term test for divergence of an infinite series.

## Theorem 6.3 The $n$ th Term Test for Divergence

If  $\lim_{n \rightarrow \infty} z_n \neq 0$ , then  $\sum_{k=1}^{\infty} z_k$  diverges.

For example, the series  $\sum_{k=1}^{\infty} (ik + 5)/k$  diverges since  $z_n = (in + 5)/n \rightarrow i \neq 0$  as  $n \rightarrow \infty$ . The geometric series (2) diverges if  $|z| \geq 1$  because even in the case when  $\lim_{n \rightarrow \infty} |z^n|$  exists, the limit is not zero.

*Handwritten:* Proof  $S_n = \sum_{k=1}^n z_k$   
 $z_n = S_n - S_{n-1}$   
 $\lim_{n \rightarrow \infty} z_n = \lim_{n \rightarrow \infty} S_n - \lim_{n \rightarrow \infty} S_{n-1} = L - L = 0$

## Definition 6.1 Absolute and Conditional Convergence

An infinite series  $\sum_{k=1}^{\infty} z_k$  is said to be **absolutely convergent** if  $\sum_{k=1}^{\infty} |z_k|$  converges. An infinite series  $\sum_{k=1}^{\infty} z_k$  is said to be **conditionally convergent** if it converges but  $\sum_{k=1}^{\infty} |z_k|$  diverges.

*Handwritten:*  $\sum \frac{(-1)^n}{n}$  is conditionally conv.

In elementary calculus a real series of the form  $\sum_{k=1}^{\infty} \frac{1}{k^p}$  is called a  **$p$ -series** and converges for  $p > 1$  and diverges for  $p \leq 1$ . We use this well-known result in the next example.

## EXAMPLE 4 Absolute Convergence

The series  $\sum_{k=1}^{\infty} \frac{i^k}{k^2}$  is absolutely convergent since the series  $\sum_{k=1}^{\infty} \left| \frac{i^k}{k^2} \right|$  is the same as the real convergent  $p$ -series  $\sum_{k=1}^{\infty} \frac{1}{k^2}$ . Here we identify  $p = 2 > 1$ .

As in real calculus:

*Absolute convergence implies convergence.*



$$\sum_{n=1}^{\infty} 2 \text{ is conv. } \left. \begin{array}{l} s_n = 2 + n + 2 = 2n \rightarrow \infty \text{ (way 1)} \\ \lim 2 = 2 \neq 0 \text{ (way 2)} \end{array} \right\} n \rightarrow \infty$$

Comparison Test If  $0 \leq a_n \leq b_n$  ( $n \in \mathbb{N}$ ) &  $\sum b_n < \infty$ , then  $\sum a_n < \infty$ .

Proof.  $\forall n; s_n = a_1 + \dots + a_n \leq b_1 + \dots + b_n = t_n$  ①  
 Since  $\sum b_n < \infty$ ,  $\{t_n\}$  is conv. Hence  $\{t_n\}$  is bounded. So  $\exists M; \forall n; t_n \leq M$  ②

If  $x_n \rightarrow x$ , then  $\{x_n\}$  is bd, since  $\exists N \forall n \geq N; |x_n - x| < 1$  ③  
 $|x_n| - |x| \leq |x_n - x| < 1$   
 $|x_n| < 1 + |x|$   
 (n = N, N+1, N+2, ...)  
 Put  $M = \max\{|x_1|, \dots, |x_{N-1}|, 1 + |x|\}$ .  
 Then  $\forall n; |x_n| \leq M$ .

Thus  $\{s_n\}$  is bd. It is increasing, since  $s_{n+1} - s_n = a_{n+1} \geq 0$ . So  $\{s_n\}$  is conv. In other words,  $\sum a_n$  is conv.  $\square$

Th. If  $\{x_n\}$  is increasing & bd, then it is convergent

Proof. <sup>real seq.</sup> Given  $\epsilon$ . Put  $x = \sup x_n$  which exists since  $\{x_1, x_2, \dots\}$  has an upper bound.  $\exists x_N; x - \epsilon < x_N$ . Since  $\{x_n\} \uparrow$ ,  $\forall n \geq N; x \geq x_n \geq x_N > x - \epsilon$ .  
 On the other hand,  $\forall n; x_n \leq x$  (since  $x = \sup x_n$ ), so  $\forall n; x_n \leq x < x + \epsilon$ .

$$x - \epsilon < x_n < x + \epsilon \Rightarrow$$

$$n \geq N \Rightarrow |x_n - x| < \epsilon. \square$$

**Tests for Convergence** Two of the most frequently used tests for convergence of infinite series are given in the next theorems.

**Theorem 6.4 Ratio Test**

Suppose  $\sum_{k=1}^{\infty} z_k$  is a series of nonzero complex terms such that

$$\lim_{n \rightarrow \infty} \left| \frac{z_{n+1}}{z_n} \right| = L. \quad (9)$$

(i) If  $L < 1$ , then the series converges absolutely.  
 (ii) If  $L > 1$  or  $L = \infty$ , then the series diverges.  
 (iii) If  $L = 1$ , the test is inconclusive.

### Theorem 6.5 Root Test

Suppose  $\sum_{k=1}^{\infty} z_k$  is a series of complex terms such that

$$\lim_{n \rightarrow \infty} \sqrt[n]{|z_n|} = L.$$

- (i) If  $L < 1$ , then the series converges absolutely. ✓
- (ii) If  $L > 1$  or  $L = \infty$ , then the series diverges.
- (iii) If  $L = 1$ , the test is inconclusive.

For  $\epsilon = 1 - L$ ,  $\exists N \forall n \geq N$ ;

$$\sqrt[n]{|z_n|} - L \leq |\sqrt[n]{|z_n|} - L| < \epsilon = 1 - L$$

$$\sqrt[n]{|z_n|} < 1$$

$$|z_n| < \alpha^n$$

Since  $\sum \alpha^n$  is conv. ( $\alpha < 1$ ),  
by Comparison Test,  
 $\sum |z_n| < \infty$ .  $\square$

We are interested primarily in applying the tests in Theorems 6.4 and 6.5 to power series.

**Power Series** The notion of a power series is important in the study of analytic functions. An infinite series of the form

Given 
$$\sum_{k=0}^{\infty} a_k (z - z_0)^k = a_0 + a_1(z - z_0) + a_2(z - z_0)^2 + \dots, \quad (11)$$

where the coefficients  $a_k$  are complex constants, is called a **power series** in  $z - z_0$ . The power series (11) is said to be **centered at  $z_0$** ; the complex point  $z_0$  is referred to as the **center** of the series. In (11) it is also convenient to define  $(z - z_0)^0 = 1$  even when  $z = z_0$ .

**Circle of Convergence** Every complex power series (11) has a **radius of convergence**. Analogous to the concept of an interval of convergence for real power series, a complex power series (11) has a **circle of convergence**, which is the circle centered at  $z_0$  of largest radius  $R > 0$  for which (11) converges at every point *within* the circle  $|z - z_0| = R$ . A power series converges absolutely at all points  $z$  within its circle of convergence, that is, for all  $z$  satisfying  $|z - z_0| < R$ , and diverges at all points  $z$  exterior to the circle, that is, for all  $z$  satisfying  $|z - z_0| > R$ . The radius of convergence can be:

- (i)  $R = 0$  (in which case (11) converges only at its center  $z = z_0$ ),
- (ii)  $R$  a finite positive number (in which case (11) converges at all interior points of the circle  $|z - z_0| = R$ ), or
- (iii)  $R = \infty$  (in which case (11) converges for all  $z$ ).

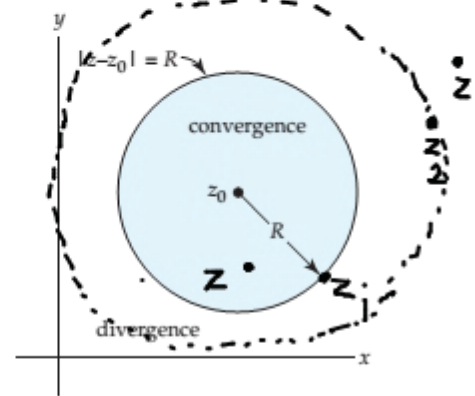

Figure 6.3 No general statement concerning convergence at points on the circle  $|z - z_0| = R$  can be made.

Assume that the series is abs. conv. at  $z_1$   
 $|z - z_0| \leq |z_1 - z_0|$   
 $|a_n (z - z_0)^n| \leq |a_n (z_1 - z_0)^n|$   
 Using the Comparison Test and noting that  $\sum |a_n (z_1 - z_0)^n| < \infty$ , we conclude that  $\sum a_n (z - z_0)^n$  is abs. conv.

As an easy consequence of the above fact is that if our power series is div. at a point  $z_2$ , then it is div. at any point outside the circle

$$|z - z_0| = |z_2 - z_0|$$

$$L = \lim_{n \rightarrow \infty} \sqrt[n]{|a_n (z - z_0)^n|} = |z - z_0| \lim_{n \rightarrow \infty} \sqrt[n]{|a_n|}$$

$< 1$  (conv.)  
 $> 1$  (div.)

$$|z - z_0| < \frac{1}{\lim_{n \rightarrow \infty} \sqrt[n]{|a_n|}} = R \text{ (radius of conv.)}$$

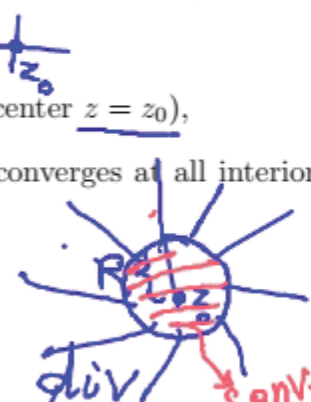

### EXAMPLE 5 Circle of Convergence

Consider the power series  $\sum_{k=1}^{\infty} \frac{z^{k+1}}{k}$ . By the ratio test (9),



$$\lim_{n \rightarrow \infty} \left| \frac{z^{n+2}}{\frac{n+1}{z^{n+1}}} \right| = \lim_{n \rightarrow \infty} \frac{n}{n+1} |z| = |z|$$

To get the radius of conv we can use the ratio Test:

Thus the series converges absolutely for  $|z| < 1$ . The circle of convergence is  $|z| = 1$  and the radius of convergence is  $R = 1$ . Note that on the circle of convergence  $|z| = 1$ , the series does not converge absolutely since  $\sum_{k=1}^{\infty} \frac{1}{k}$  is the well-known divergent harmonic series. Bear in mind *this does not say* that the series diverges on the circle of convergence. In fact, at  $z = -1$ ,  $\sum_{k=1}^{\infty} \frac{(-1)^{k+1}}{k}$  is the convergent alternating harmonic series. Indeed, it can be shown that the series converges at all points on the circle  $|z| = 1$  *except* at  $z = 1$ .

Handwritten notes and formulas:

$$\frac{1}{R} = \lim_{n \rightarrow \infty} \left| \frac{a_{n+1}}{a_n} \right| = \lim_{n \rightarrow \infty} \sqrt[n]{|a_n|}$$

$$\lim_{n \rightarrow \infty} \left| \frac{a_n}{a_{n+1}} \right|$$

### EXAMPLE 6 Radius of Convergence

Consider the power series  $\sum_{k=1}^{\infty} \frac{(-1)^{k+1}}{k!} (z - 1 - i)^k$ . With the identification  $a_n = (-1)^{n+1}/n!$  we have

$$\lim_{n \rightarrow \infty} \left| \frac{(-1)^{n+2}}{(n+1)!} \frac{(-1)^{n+1}}{n!} \right| = \lim_{n \rightarrow \infty} \frac{1}{n+1} = 0$$

Hence by (13) the radius of convergence is  $\infty$ ; the power series with center  $z_0 = 1 + i$  converges absolutely for all  $z$ , that is, for  $|z - 1 - i| < \infty$ .

Notation

$$\frac{1}{0} = \infty$$

Let  $\sum a_n$  &  $\sum b_n$  are conv. &  $\alpha, \beta \in \mathbb{C}$ . Then  $\sum \alpha a_n + \beta b_n$  is conv.

### EXAMPLE 7 Radius of Convergence

Consider the power series  $\sum_{k=1}^{\infty} \left( \frac{6k+1}{2k+5} \right)^k (z-2i)^k$ . With  $a_n = \left( \frac{6n+1}{2n+5} \right)^n$ , the root test in the form (15) gives

$$\lim_{n \rightarrow \infty} \sqrt[n]{|a_n|} = \lim_{n \rightarrow \infty} \frac{6n+1}{2n+5} = 3$$

By reasoning similar to that leading to (12), we conclude that the radius of convergence of the series is  $R = \frac{1}{3}$ . The circle of convergence is  $|z - 2i| = \frac{1}{3}$ ; the power series converges absolutely for  $|z - 2i| < \frac{1}{3}$ .

Proof:

$$\sum_{k=1}^n (\alpha a_k + \beta b_k) = \alpha \sum_{k=1}^n a_k + \beta \sum_{k=1}^n b_k$$

Handwritten notes:

$$|z - z_0| < R_1 \quad |z - z_0| < R_2 \quad |z - z_0| < \min\{R_1, R_2\}$$

$$\sum_{k=0}^{\infty} a_k (z - z_0)^k \pm \sum_{k=0}^{\infty} b_k (z - z_0)^k = \sum_{k=0}^{\infty} (a_k \pm b_k) (z - z_0)^k$$

(i) If  $z_n = a_n + ib_n$  then the  $n$ th term of the sequence of partial sums for  $\sum_{k=1}^{\infty} z_k$  can be written  $S_n = \sum_{k=1}^n (a_k + ib_k) = \sum_{k=1}^n a_k + i \sum_{k=1}^n b_k$ . Analogous to Theorem 6.2,  $\sum_{k=1}^{\infty} z_k$  converges to a number  $L = a + ib$  if and only if  $\text{Re}(S_n) = \sum_{k=1}^n a_k$  converges to

# Differentiation and Integration of Power Series

The three theorems that follow indicate a function  $f$  that is defined by a power series is continuous, differentiable, and integrable within its circle of convergence.

## Theorem 6.6 Continuity

A power series  $\sum_{k=0}^{\infty} a_k(z - z_0)^k$  represents a continuous function  $f$  within its circle of convergence  $|z - z_0| = R$ .

## Theorem 6.7 Term-by-Term Differentiation

A power series  $\sum_{k=0}^{\infty} a_k(z - z_0)^k$  can be differentiated term by term within its circle of convergence  $|z - z_0| = R$ .

Differentiating a power series term-by-term gives,

$$f'(z) = \frac{d}{dz} \sum_{k=0}^{\infty} a_k(z - z_0)^k = \sum_{k=0}^{\infty} a_k \frac{d}{dz} (z - z_0)^k = \sum_{k=1}^{\infty} a_k k (z - z_0)^{k-1}$$

## Theorem 6.8 Term-by-Term Integration

A power series  $\sum_{k=0}^{\infty} a_k(z - z_0)^k$  can be integrated term-by-term within its circle of convergence  $|z - z_0| = R$ , for every contour  $C$  lying entirely within the circle of convergence.

The theorem states that

$$\int_C \sum_{k=0}^{\infty} a_k(z - z_0)^k dz = \sum_{k=0}^{\infty} a_k \int_C (z - z_0)^k dz$$

whenever  $C$  lies in the interior of  $|z - z_0| = R$ . Indefinite integration can also be carried out term by term:

$$\int \sum_{k=0}^{\infty} a_k(z - z_0)^k dz = \sum_{k=0}^{\infty} a_k \int (z - z_0)^k dz = \sum_{k=0}^{\infty} \frac{a_k}{k+1} (z - z_0)^{k+1} + \text{constant}$$

The ratio test given in Theorem 6.4 can be used to be prove that both

$$\sum_{k=0}^{\infty} a_k(z - z_0)^k \quad \text{and} \quad \sum_{k=0}^{\infty} \frac{a_k}{k+1} (z - z_0)^{k+1} \quad \text{have the same circle of convergence}$$

The A power series  $\sum_{n=0}^{\infty} a_n(z-z_0)^n$  is uniformly conv. in any compact subset of its circle of conv.  
 Proof  $\sum_{n=0}^{\infty} a_n(z-z_0)^n = f_n(z)$



The function  $\phi(z) = |z - z_0|$  is cts &  $K$  is compact, so  $\exists \epsilon_K, \delta_K$  s.t.  $|z - z_0| \leq |z - z_0| + \delta_K$

Hence  $|a_n(z-z_0)^n| \leq |a_n(z-z_0)^n|$   
 Since  $\sum M_n < \infty$ , by the M-Weierstrass test,  $\sum a_n(z-z_0)^n$  is uniformly conv. on  $K$ .

Because of the cts of  $a_n(z-z_0)^n$  and the uniformly conv. we can say that the function  $f(z) = \sum_{n=0}^{\infty} a_n(z-z_0)^n$  is cts on  $K$ .

If  $K$  is a singleton  $\{z\}$  we can say that  $\sum a_n(z-z_0)^n$  is cts at  $z_2$  (an arbitrary point inside the circle of conv.)

## Taylor Series

Suppose a power series represents a function  $f$  within  $|z - z_0| = R$ , that is,

$$f(z) = \sum_{k=0}^{\infty} a_k (z - z_0)^k = a_0 + a_1(z - z_0) + a_2(z - z_0)^2 + a_3(z - z_0)^3 + \cdots \quad (1)$$

It follows from Theorem 6.7 that the derivatives of  $f$  are the series

$$f'(z) = \sum_{k=1}^{\infty} a_k k (z - z_0)^{k-1} = a_1 + 2a_2(z - z_0) + 3a_3(z - z_0)^2 + \cdots, \quad (2) \quad \rightsquigarrow f'(z_0) = a_1$$

$$f''(z) = \sum_{k=2}^{\infty} a_k k(k-1)(z - z_0)^{k-2} = 2 \cdot 1a_2 + 3 \cdot 2a_3(z - z_0) + \cdots, \quad (3) \quad \rightsquigarrow f''(z_0) = 2a_2$$

$$f'''(z) = \sum_{k=3}^{\infty} a_k k(k-1)(k-2)(z - z_0)^{k-3} = 3 \cdot 2 \cdot 1a_3 + \cdots, \quad (4) \quad \rightsquigarrow f'''(z_0) = 6a_3$$

and so on. Since the power series (1) represents a differentiable function  $f$  within its circle of convergence  $|z - z_0| = R$ , where  $R$  is either a positive number or infinity, we conclude that a *power series represents an analytic function* within its circle of convergence.

There is a relationship between the coefficients  $a_k$  in (1) and the derivatives of  $f$ . Evaluating (1), (2), (3), and (4) at  $z = z_0$  gives

$$f(z_0) = a_0, \quad f'(z_0) = 1!a_1, \quad f''(z_0) = 2!a_2, \quad \text{and} \quad f'''(z_0) = 3!a_3,$$

respectively. In general,  $f^{(n)}(z_0) = n!a_n$  or

$$a_n = \frac{f^{(n)}(z_0)}{n!}, \quad n \geq 0. \quad (5)$$

When  $n = 0$  in (5), we interpret the zero-order derivative as  $f(z_0)$  and  $0! = 1$  so that the formula gives  $a_0 = f(z_0)$ . Substituting (5) into (1) yields

$$f(z) = \sum_{k=0}^{\infty} \frac{f^{(k)}(z_0)}{k!} (z - z_0)^k = \sum_{k=0}^{\infty} a_k (z - z_0)^k \quad (6)$$

This series is called the **Taylor series** for  $f$  centered at  $z_0$ . A Taylor series with center  $z_0 = 0$ ,

$$f(z) = \sum_{k=0}^{\infty} \frac{f^{(k)}(0)}{k!} z^k, \quad (7)$$

is referred to as a **Maclaurin series**.

We have just seen that a power series with a nonzero radius  $R$  of convergence represents an analytic function. On the other hand we ask:

### Question

If we are given a function  $f$  that is analytic in some domain  $D$ , can we represent it by a power series of the form (6) or (7)?

## Theorem 6.9 Taylor's Theorem

Let  $f$  be analytic within a domain  $D$  and let  $z_0$  be a point in  $D$ . Then  $f$  has the series representation

$$f(z) = \sum_{k=0}^{\infty} \frac{f^{(k)}(z_0)}{k!} (z - z_0)^k \quad (8)$$

valid for the largest circle  $C$  with center at  $z_0$  and radius  $R$  that lies entirely within  $D$ .

### Some Important Maclaurin Series

$$e^z = 1 + \frac{z}{1!} + \frac{z^2}{2!} + \cdots = \sum_{k=0}^{\infty} \frac{z^k}{k!} \quad (12)$$

$$\sin z = z - \frac{z^3}{3!} + \frac{z^5}{5!} - \cdots = \sum_{k=0}^{\infty} (-1)^k \frac{z^{2k+1}}{(2k+1)!} \quad (13)$$

$$\cos z = 1 - \frac{z^2}{2!} + \frac{z^4}{4!} - \cdots = \sum_{k=0}^{\infty} (-1)^k \frac{z^{2k}}{(2k)!} \quad (14)$$

### EXAMPLE 1 Radius of Convergence

Suppose the function  $f(z) = \frac{3-i}{1-i+z}$  is expanded in a Taylor series with center  $z_0 = 4 - 2i$ . What is its radius of convergence  $R$ ?

**Solution** Observe that the function is analytic at every point except at  $z = -1 + i$ , which is an isolated singularity of  $f$ . The distance from  $z = -1 + i$  to  $z_0 = 4 - 2i$  is

$$|z - z_0| = \sqrt{(-1-4)^2 + (1-(-2))^2} = \sqrt{34}$$

If two power series with center  $z_0$ ,

$$f(z) = \sum_{k=0}^{\infty} a_k (z - z_0)^k \quad \text{and} \quad \sum_{k=0}^{\infty} b_k (z - z_0)^k$$

represent the same function  $f$  and have the same nonzero radius  $R$  of convergence, then

$$a_k = b_k = \frac{f^{(k)}(z_0)}{k!}, \quad k = 0, 1, 2, \dots$$

Stated in another way, the power series expansion of a function, with center  $z_0$ , is *unique*. On a practical level this means that a power series expansion of an analytic function  $f$  centered at  $z_0$ , irrespective of the method used to obtain it, is *the* Taylor series expansion of the function. For example, we can obtain (14) by simply differentiating (13) term by term. The Maclaurin series for  $e^{z^2}$  can be obtained by replacing the symbol  $z$  in (12) by  $z^2$ .

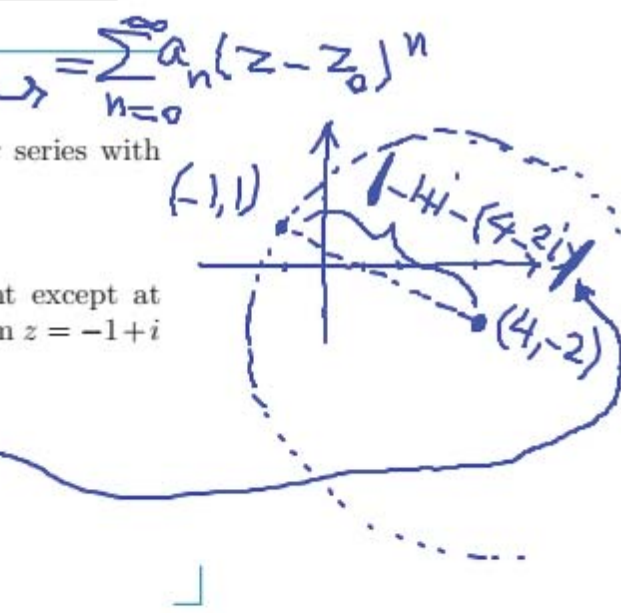

If you can represent a function  $f$  as a power series  $\sum_n a_n (z - z_0)^n$  then this series is the Taylor series of  $f$  at  $z_0$ .

### EXAMPLE 2 Maclaurin Series

Find the Maclaurin expansion of  $f(z) = \frac{1}{(1-z)^2}$ .

**Solution** We could, of course, begin by computing the coefficients using (8). However, recall from (6) of Section 6.1 that for  $|z| < 1$ ,

$$\frac{1}{1-z} = 1 + z + z^2 + z^3 + \dots$$

If we differentiate both sides of the last result with respect to  $z$ , then

$$\frac{d}{dz} \frac{1}{1-z} = \frac{d}{dz} 1 + \frac{d}{dz} z + \frac{d}{dz} z^2 + \frac{d}{dz} z^3 + \dots$$

or 
$$\frac{1}{(1-z)^2} = 0 + 1 + 2z + 3z^2 + \dots = \sum_{k=1}^{\infty} k z^{k-1}. \quad (16)$$

Since we are using Theorem 6.7, the radius of convergence of the last power series is the same as the original series,  $R = 1$ .

We can often build on results such as (16). For example, if we want the Maclaurin expansion of  $f(z) = \frac{z^3}{(1-z)^2}$ , we simply multiply (16) by  $z^3$ :

$$\frac{z^3}{(1-z)^2} = z^3 + 2z^4 + 3z^5 + \dots = \sum_{k=1}^{\infty} k z^{k+2}.$$

The radius of convergence of the last series is still  $R = 1$ .

### EXAMPLE 3 Taylor Series

Expand  $f(z) = \frac{1}{1-z}$  in a Taylor series with center  $z_0 = 2i$ .

**Solution** In this solution we again use the geometric series (15). By adding and subtracting  $2i$  in the denominator of  $1/(1-z)$ , we can write

$$\frac{1}{1-z} = \frac{1}{1-z+2i-2i} = \frac{1}{1-2i-(z-2i)} = \frac{1}{1-2i} \frac{1}{1-\frac{z-2i}{1-2i}}$$

We now write  $\frac{1}{1-\frac{z-2i}{1-2i}}$  as a power series by using (15) with the symbol  $z$

replaced by the expression  $\frac{z-2i}{1-2i}$ :

$$\frac{1}{1-z} = \frac{1}{1-2i} \left[ 1 + \frac{z-2i}{1-2i} + \left( \frac{z-2i}{1-2i} \right)^2 + \left( \frac{z-2i}{1-2i} \right)^3 + \dots \right]$$

Handwritten notes for Example 2:

$$\frac{1}{1-z} = \sum_{n=0}^{\infty} z^n \quad (|z| < 1)$$
$$\left( \frac{1}{1-z} \right)^2 = \left( \sum_{n=0}^{\infty} z^n \right)^2 = \sum_{n=1}^{\infty} n z^{n-1} \quad (|z| < 1)$$

Handwritten notes for Example 2 (continued):

$$\left( \frac{1}{1-z} \right)^2 = \sum_{n=1}^{\infty} n z^{n-1}$$
$$\frac{z^3}{(1-z)^2} = \sum_{n=1}^{\infty} n z^{n+2}$$

Handwritten notes for Example 3:

$$\frac{1}{1-z} = \frac{1}{1-z+2i-2i} = \frac{1}{1-2i-(z-2i)} = \frac{1}{1-2i} \frac{1}{1-\frac{z-2i}{1-2i}}$$
$$= \frac{1}{1-2i} \sum_{n=0}^{\infty} \left( \frac{z-2i}{1-2i} \right)^n = \sum_{n=0}^{\infty} \frac{1}{(1-2i)^{n+1}} (z-2i)^n$$

in the neighborhood defined by  $|z - 2i| < 1$ , except at  $z = 2i$ , and at every point in the neighborhood defined by  $|z - (-2i)| < 1$ , except at  $z = -2i$ . In other words,  $f$  is analytic in the deleted neighborhoods  $0 < |z - 2i| < 1$  and  $0 < |z + 2i| < 1$ . On the other hand, the branch point  $z = 0$  is *not* an isolated singularity of  $\text{Ln } z$  since every neighborhood of  $z = 0$  must contain points on the negative  $x$ -axis. We say that a singular point  $z = z_0$  of a function  $f$  is **nonisolated** if every neighborhood of  $z_0$  contains at least one singularity of  $f$  other than  $z_0$ . For example, the branch point  $z = 0$  is a nonisolated singularity of  $\text{Ln } z$  since every neighborhood of  $z = 0$  contains points on the negative real axis.

**A New Kind of Series** If  $z = z_0$  is a singularity of a function  $f$ , then certainly  $f$  cannot be expanded in a power series with  $z_0$  as its center. However, about an isolated singularity  $z = z_0$ , it is possible to represent  $f$  by a series involving both negative and nonnegative integer powers of  $z - z_0$ ; that is,

$$f(z) = \dots + \frac{a_{-2}}{(z - z_0)^2} + \frac{a_{-1}}{z - z_0} + a_0 + a_1(z - z_0) + a_2(z - z_0)^2 + \dots \quad (1)$$

As a *very* simple example of (1) let us consider the function  $f(z) = 1/(z - 1)$ . As can be seen, the point  $z = 1$  is an isolated singularity of  $f$  and consequently the function cannot be expanded in a Taylor series centered at that point. Nevertheless,  $f$  can be expanded in a series of the form given in (1) that is valid for all  $z$  near 1:

$$f(z) = \dots + \frac{0}{(z - 1)^2} + \frac{1}{z - 1} + 0 + 0 \cdot (z - 1) + 0 \cdot (z - 1)^2 + \dots \quad (2)$$

The series representation in (2) is valid for  $0 < |z - 1| < \infty$ .

Using summation notation, we can write (1) as the sum of two series

$$f(z) = \underbrace{\sum_{k=1}^{\infty} a_{-k}(z - z_0)^{-k}}_{\text{Principal part}} + \underbrace{\sum_{k=0}^{\infty} a_k(z - z_0)^k}_{\text{analytic part}} \quad (3)$$

The two series on the right-hand side in (3) are given special names. The part with negative powers of  $z - z_0$ , that is,

$$\sum_{k=1}^{\infty} a_{-k}(z - z_0)^{-k} = \sum_{k=1}^{\infty} \frac{a_{-k}}{(z - z_0)^k} \quad (4)$$

is called the **principal part** of the series (1) and will converge for  $|1/(z - z_0)| < r^*$  or equivalently for  $|z - z_0| > 1/r^* = r$ . The part consisting of the nonnegative powers of  $z - z_0$ ,

$$\sum_{k=0}^{\infty} a_k(z - z_0)^k, \quad (5)$$

is called the **analytic part** of the series (1) and will converge for  $|z - z_0| < R$ . Hence, the sum of (4) and (5) converges when  $z$  satisfies both  $|z - z_0| > r$  and  $|z - z_0| < R$ , that is, when  $z$  is a point in an annular domain defined by  $r < |z - z_0| < R$ .

By summing over negative and nonnegative integers, (1) can be written compactly as

$$f(z) = \sum_{k=-\infty}^{\infty} a_k(z - z_0)^k.$$



$f$  is not analytic at  $z_0$  but it is analytic at each point of a deleted nbd of  $z_0$ . Then  $z_0$  is called an isolated singular point.

Example:  $f(z) = \frac{1}{z}$

In other words:

A singular point is isolated if

$\exists N(z) \cap \{z_0\} \cap \{z \in N(z_0) : f \text{ is analytic at } z\} \neq \emptyset$

otherwise

$\forall N(z) \cap \{z_0\} \cap \{z \in N(z_0) : f \text{ is not analytic}\} \neq \emptyset$



$r < \infty \Rightarrow 0 < |z - z_0| < R$

$R = \infty \Rightarrow r < |z - z_0|$



### EXAMPLE 1 Series of the Form Given in (1)

The function  $f(z) = \frac{\sin z}{z^4}$  is not analytic at the isolated singularity  $z = 0$  and hence cannot be expanded in a Maclaurin series. However,  $\sin z$  is an entire function, and from (13) of Section 6.2 we know that its Maclaurin series,

$$\sin z = z - \frac{z^3}{3!} + \frac{z^5}{5!} - \frac{z^7}{7!} + \frac{z^9}{9!} - \dots, \quad z \in \mathbb{C}$$

converges for  $|z| < \infty$ . By dividing this power series by  $z^4$  we obtain a series for  $f$  with negative and positive integer powers of  $z$ :

$$f(z) = \frac{\sin z}{z^4} = \underbrace{\frac{1}{z^3} - \frac{1}{3!z}}_{\text{principal part}} + \underbrace{\frac{z}{5!} - \frac{z^3}{7!} + \frac{z^5}{9!} - \dots}_{\text{analytic part}}. \quad z \neq 0 \quad (6)$$



The analytic part of the series in (6) converges for  $|z| < \infty$ . (Verify.) The principal part is valid for  $|z| > 0$ . Thus (6) converges for all  $z$  except at  $z = 0$ ; that is, the series representation is valid for  $0 < |z| < \infty$ .

A series representation of a function  $f$  that has the form given in (1), and (2) and (6) are such examples, is called a **Laurent series** or a **Laurent expansion** of  $f$  about  $z_0$  on the annulus  $r < |z - z_0| < R$ .

#### Theorem 6.10 Laurent's Theorem

Let  $f$  be analytic within the annular domain  $D$  defined by  $r < |z - z_0| < R$ . Then  $f$  has the series representation

$$f(z) = \sum_{k=-\infty}^{\infty} a_k (z - z_0)^k \quad (7)$$

valid for  $r < |z - z_0| < R$ . The coefficients  $a_k$  are given by

$$a_k = \frac{1}{2\pi i} \oint_C \frac{f(s)}{(s - z_0)^{k+1}} ds, \quad k = 0, \pm 1, \pm 2, \dots, \quad (8)$$

where  $C$  is a simple closed curve that lies entirely within  $D$  and has  $z_0$  in its interior. See Figure 6.6.

### EXAMPLE 2 Four Laurent Expansions

Expand  $f(z) = \frac{1}{z(z-1)}$  in a Laurent series valid for the following annular domains.

- (a)  $0 < |z| < 1$       (b)  $1 < |z|$       (c)  $0 < |z-1| < 1$       (d)  $1 < |z-1|$

**Solution** The four specified annular domains are shown in Figure 6.8. The black dots in each figure represent the two isolated singularities,  $z = 0$  and  $z = 1$ , of  $f$ . In parts (a) and (b) we want to represent  $f$  in a series involving only negative and nonnegative integer powers of  $z$ , whereas in parts (c) and (d) we want to represent  $f$  in a series involving negative and nonnegative integer powers of  $z - 1$ .

(a) By writing

$$f(z) = -\frac{1}{z} \frac{1}{1-z},$$

we can use (6) of Section 6.1 to write  $1/(1-z)$  as a series:

$$f(z) = -\frac{1}{z} [1 + z + z^2 + z^3 + \dots].$$

The infinite series in the brackets converges for  $|z| < 1$ , but after we multiply this expression by  $1/z$ , the resulting series

$$f(z) = -\frac{1}{z} - 1 - z - z^2 - z^3 - \dots$$

converges for  $0 < |z| < 1$ .

(b) To obtain a series that converges for  $1 < |z|$ , we start by constructing a series that converges for  $|1/z| < 1$ . To this end we write the given function  $f$  as

$$f(z) = \frac{1}{z^2} \frac{1}{1 - \frac{1}{z}}$$

and again use (6) of Section 6.1 with  $z$  replaced by  $1/z$ :

$$f(z) = \frac{1}{z^2} \left[ 1 + \frac{1}{z} + \frac{1}{z^2} + \frac{1}{z^3} + \dots \right].$$

The series in the brackets converges for  $|1/z| < 1$  or equivalently for  $1 < |z|$ . Thus the required Laurent series is

$$f(z) = \frac{1}{z^2} + \frac{1}{z^3} + \frac{1}{z^4} + \frac{1}{z^5} + \dots$$

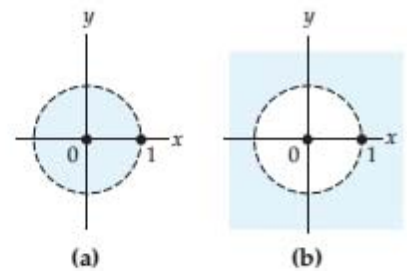

Handwritten notes and diagrams:

Diagram (a) is labeled with  $|z| < 1$  and  $|z-1| < 1$  with arrows pointing to the circles.

Diagram (b) is labeled with  $1 < |z|$  and  $1 < |z-1|$  with arrows pointing to the region outside the circle.

Handwritten derivation for (a):

$$f(z) = \frac{-1}{z} \cdot \frac{1}{1-z}$$

$$= \sum_{n=0}^{\infty} -z^{n-1}$$

Handwritten derivation for (b):

$$f(z) = \frac{1}{z^2} \cdot \frac{1}{z-1}$$

$$= \frac{1}{z^2} \cdot \frac{1}{1 - \frac{1}{z}}$$

with a note  $|1/z| < 1$  and a circled  $1/z$  in the denominator.

- (c) This is basically the same problem as in part (a), except that we want all powers of  $z - 1$ . To that end, we add and subtract 1 in the denominator and use (7) of Section 6.1 with  $z$  replaced by  $z - 1$ :

$$\begin{aligned} f(z) &= \frac{1}{(1-1+z)(z-1)} \\ &= \frac{1}{z-1} \frac{1}{1+(z-1)} = \frac{1}{z-1} - \frac{1}{1-(-(z-1))} \\ &= \frac{1}{z-1} [1 - (z-1) + (z-1)^2 - (z-1)^3 + \dots] \\ &= \frac{1}{z-1} - 1 + (z-1) - (z-1)^2 + \dots \end{aligned}$$

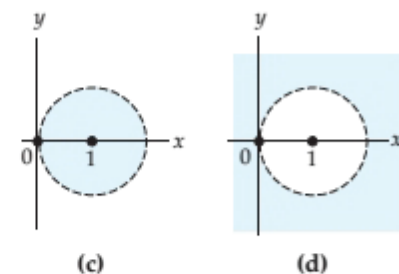

Figure 6.8 Annular domains for Example 2

The requirement that  $z \neq 1$  is equivalent to  $0 < |z - 1|$ , and the geometric series in brackets converges for  $|z - 1| < 1$ . Thus the last series converges for  $z$  satisfying  $0 < |z - 1|$  and  $|z - 1| < 1$ , that is, for  $0 < |z - 1| < 1$ .

$$\frac{1}{1-\omega} = \sum_{n=0}^{\infty} \omega^n$$

- (d) Proceeding as in part (b), we write

$$\begin{aligned} f(z) &= \frac{1}{z-1} \frac{1}{1+(z-1)} = \frac{1}{(z-1)^2} \frac{1}{1+\frac{1}{z-1}} \\ &= \frac{1}{(z-1)^2} \left[ 1 - \frac{1}{z-1} + \frac{1}{(z-1)^2} - \frac{1}{(z-1)^3} + \dots \right] \\ &= \frac{1}{(z-1)^2} - \frac{1}{(z-1)^3} + \frac{1}{(z-1)^4} - \frac{1}{(z-1)^5} + \dots \end{aligned}$$

Because the series within the brackets converges for  $|1/(z-1)| < 1$ , the final series converges for  $1 < |z - 1|$ .

### EXAMPLE 3 Laurent Expansions

Expand  $f(z) = \frac{1}{(z-1)^2(z-3)}$  in a Laurent series valid for (a)  $0 < |z - 1| < 2$

$$\left| \frac{z-1}{2} \right| < 1$$

#### Solution

- (a) As in parts (c) and (d) of Example 2, we want only powers of  $z - 1$  and so we need to express  $z - 3$  in terms of  $z - 1$ . This can be done by writing

$$f(z) = \frac{1}{(z-1)^2(z-3)} = \frac{1}{(z-1)^2} \frac{1}{-2+(z-1)} = \frac{-1}{2(z-1)^2} \frac{1}{1-\frac{z-1}{2}}$$

and then using (6) of Section 6.1 with the symbol  $z$  replaced by  $(z-1)/2$ ,

$$\begin{aligned} f(z) &= \frac{-1}{2(z-1)^2} \left[ 1 + \frac{z-1}{2} + \frac{(z-1)^2}{2^2} + \frac{(z-1)^3}{2^3} + \dots \right] \\ &= -\frac{1}{2(z-1)^2} - \frac{1}{4(z-1)} - \frac{1}{8} - \frac{1}{16}(z-1) - \dots \end{aligned} \quad (16)$$

**EXAMPLE 5 A Laurent Expansion**

Expand  $f(z) = \frac{1}{z(z-1)}$  in a Laurent series valid for  $1 < |z-2| < 2$ .

**Solution** The specified annular domain is shown in Figure 6.9. The center of this domain,  $z = 2$ , is the point of analyticity of the function  $f$ . Our goal now is to find two series involving integer powers of  $z - 2$ , one converging for  $1 < |z - 2|$  and the other converging for  $|z - 2| < 2$ . To accomplish this, we proceed as in the last example by decomposing  $f$  into partial fractions:

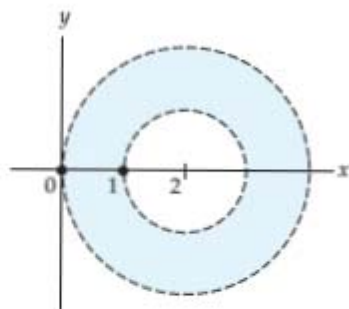

$$f(z) = -\frac{1}{z} + \frac{1}{z-1} = f_1(z) + f_2(z). \quad (17)$$

Now, 
$$f_1(z) = -\frac{1}{z} = -\frac{1}{2+z-2}$$

$$= -\frac{1}{2} \frac{1}{1 + \frac{z-2}{2}}$$

$$= -\frac{1}{2} \left[ 1 - \frac{z-2}{2} + \frac{(z-2)^2}{2^2} - \frac{(z-2)^3}{2^3} + \dots \right]$$

$$= -\frac{1}{2} + \frac{z-2}{2^2} - \frac{(z-2)^2}{2^3} + \frac{(z-2)^3}{2^4} - \dots$$

This series converges for  $|(z-2)/2| < 1$  or  $|z-2| < 2$ . Furthermore,

$$\begin{aligned} f_2(z) &= \frac{1}{z-1} = \frac{1}{1+z-2} = \frac{1}{z-2} \frac{1}{1 + \frac{1}{z-2}} \\ &= \frac{1}{z-2} \left[ 1 - \frac{1}{z-2} + \frac{1}{(z-2)^2} - \frac{1}{(z-2)^3} + \dots \right] \\ &= \frac{1}{z-2} - \frac{1}{(z-2)^2} + \frac{1}{(z-2)^3} - \frac{1}{(z-2)^4} + \dots \end{aligned}$$

converges for  $|1/(z-2)| < 1$  or  $1 < |z-2|$ . Substituting these two results in (17) then gives

This representation is valid for  $z$  satisfying  $|z-2| < 2$  and  $1 < |z-2|$ ; in other words, for  $1 < |z-2| < 2$ .

$$f(z) = \dots - \frac{1}{(z-2)^4} + \frac{1}{(z-2)^3} - \frac{1}{(z-2)^2} + \frac{1}{z-2} - \frac{1}{2} + \frac{z-2}{2^2} - \frac{(z-2)^2}{2^3} + \frac{(z-2)^3}{2^4} - \dots$$

**EXAMPLE 6 A Laurent Expansion**

Expand  $f(z) = e^{3/z}$  in a Laurent series valid for  $0 < |z| < \infty$ .

**Solution** From (12) of Section 6.2 we know that for all finite  $z$ , that is,  $|z| < \infty$ ,

$$e^z = 1 + z + \frac{z^2}{2!} + \frac{z^3}{3!} + \dots \quad (18)$$

We obtain the Laurent series for  $f$  by simply replacing  $z$  in (18) by  $3/z$ ,  $z \neq 0$ ,

$$e^{3/z} = 1 + \frac{3}{z} + \frac{3^2}{2!z^2} + \frac{3^3}{3!z^3} + \dots \quad \text{This series (19) is valid for } z \neq 0, \text{ that is, for } 0 < |z| < \infty.$$

## Classification of Isolated Singular Points

An isolated singular point  $z = z_0$  of a complex function  $f$  is given a classification depending on whether the principal part (2) of its Laurent expansion (1) contains zero, a finite number, or an infinite number of terms.

  
 $f$  is analytic except  $z_0$   
 (Isolated Singular point)

- (i) If the principal part is zero, that is, all the coefficients  $a_{-k}$  in (2) are zero, then  $z = z_0$  is called a **removable singularity**.
- (ii) If the principal part contains a finite number of nonzero terms, then  $z = z_0$  is called a **pole**. If, in this case, the last nonzero coefficient in (2) is  $a_{-n}$ ,  $n \geq 1$ , then we say that  $z = z_0$  is a **pole of order  $n$** . If  $z = z_0$  is pole of order 1, then the principal part (2) contains exactly one term with coefficient  $a_{-1}$ . A pole of order 1 is commonly called a **simple pole**.
- (iii) If the principal part (2) contains an infinitely many nonzero terms, then  $z = z_0$  is called an **essential singularity**.

Table 6.1 summarizes the form of a Laurent series for a function  $f$  when  $z = z_0$  is one of the above types of isolated singularities. Of course,  $R$  in the table could be  $\infty$ .

$z = z_0$	Laurent Series for $0 <  z - z_0  < R$
Removable singularity	$a_0 + a_1(z - z_0) + a_2(z - z_0)^2 + \dots$
Pole of order $n$	$\frac{a_{-n}}{(z - z_0)^n} + \frac{a_{-(n-1)}}{(z - z_0)^{n-1}} + \dots + \frac{a_{-1}}{z - z_0} + a_0 + a_1(z - z_0) + \dots$
Simple pole	$\frac{a_{-1}}{z - z_0} + a_0 + a_1(z - z_0) + a_2(z - z_0)^2 + \dots$
Essential singularity	$\dots + \frac{a_{-2}}{(z - z_0)^2} + \frac{a_{-1}}{z - z_0} + a_0 + a_1(z - z_0) + a_2(z - z_0)^2 + \dots$

*Handwritten notes:*  
 if you define  $f(z) = a_0$  then  $f(z) = a_0 + a_1(z - z_0) + \dots$  is analytic.  
 $f(z) = 1 + z + \frac{z^2}{2!} + \dots$   
 $0 < |z| < \infty$   
 $f(0) = 1$   
 $f(z) = \sum_{n=0}^{\infty} \frac{z^n}{n!} = e^z$

Table 6.1 Forms of Laurent series

### EXAMPLE 1 Removable Singularity

Proceeding as we did in Example 1 of Section 6.3 by dividing the Maclaurin series for  $\sin z$  by  $z$ , we see from

$$f(z) = \frac{\sin z}{z} = 1 - \frac{z^2}{3!} + \frac{z^4}{5!} - \dots \quad (3)$$

*Handwritten:  $\sin z = z - \frac{z^3}{3!} + \frac{z^5}{5!} - \dots$*

that all the coefficients in the principal part of the Laurent series are zero. Hence  $z = 0$  is a removable singularity of the function  $f(z) = (\sin z)/z$ .

*Handwritten: if  $f(0) = 1$ , then  $f$  becomes analytic at  $z = 0$ .*

### EXAMPLE 2 Poles and Essential Singularity

- (a) Dividing the terms of  $\sin z = z - \frac{z^3}{3!} + \frac{z^5}{5!} - \dots$  by  $z^2$  shows that

$$\frac{\sin z}{z^2} = \overbrace{\frac{1}{z}}^{\text{principal part}} - \frac{z}{3!} + \frac{z^3}{5!} - \dots$$

for  $0 < |z| < \infty$ . From this series we see that  $a_{-1} \neq 0$  and so  $z = 0$  is a simple pole of the function  $f(z) = (\sin z)/z^2$ . In like manner, we see that  $z = 0$  is a pole of order 3 of the function  $f(z) = (\sin z)/z^4$  considered in Example 1 of Section 6.3.

(b) In Example 3 of Section 6.3 we showed that the Laurent expansion of  $f(z) = 1/(z-1)^2(z-3)$  valid for  $0 < |z-1| < 2$  was

$$f(z) = \underbrace{-\frac{1}{2(z-1)^2} - \frac{1}{4(z-1)} - \frac{1}{8} - \frac{z-1}{16} - \dots}_{\text{principal part}}$$

$f(z) = \frac{1}{(z-1)^2} \cdot \frac{1}{z-3}$   
 $-2 \left( 1 - \frac{(z-1)}{2} \right)$

Since  $a_{-2} = -\frac{1}{2} \neq 0$ , we conclude that  $z = 1$  is a pole of order 2.

(c) In Example 6 of Section 6.3 we see from (19) that the principal part of the Laurent expansion of the function  $f(z) = e^{3/z}$  valid for  $0 < |z| < \infty$  contains an infinite number of nonzero terms. This shows that  $z = 0$  is an essential singularity of  $f$ .

$$\sum_{n=0}^{\infty} \frac{(3/z)^n}{n!}$$

$$= \dots + \frac{9}{2z^2} + \frac{3}{z} + 1$$

Principal part

**Zeros** Recall, a number  $z_0$  is **zero** of a function  $f$  if  $f(z_0) = 0$ . We say that an analytic function  $f$  has a **zero of order  $n$**  at  $z = z_0$  if

$z_0$  is a zero of  $f$  and of its first  $n-1$  derivatives

$$f(z_0) = 0, f'(z_0) = 0, f''(z_0) = 0, \dots, f^{(n-1)}(z_0) = 0, \text{ but } f^{(n)}(z_0) \neq 0. \quad (4)$$

A zero of order  $n$  is also referred to as a **zero of multiplicity  $n$** . For example, for  $f(z) = (z-5)^3$  we see that  $f(5) = 0, f'(5) = 0, f''(5) = 0$ , but  $f'''(5) = 6 \neq 0$ . Thus  $f$  has a zero of order (or multiplicity) 3 at  $z_0 = 5$ . A zero of order 1 is called a **simple zero**.

The next theorem is a consequence of (4).

**Theorem 6.11 Zero of Order  $n$**

A function  $f$  that is analytic in some disk  $|z - z_0| < R$  has a zero of order  $n$  at  $z = z_0$  if and only if  $f$  can be written

$$f(z) = (z - z_0)^n \phi(z), \quad (5)$$

where  $\phi$  is analytic at  $z = z_0$  and  $\phi(z_0) \neq 0$ .

**Partial Proof** We will establish the "only if" part of the theorem. Given that  $f$  is analytic at  $z_0$ , it can be expanded in a Taylor series that is centered at  $z_0$  and is convergent for  $|z - z_0| < R$ . Since the coefficients in a Taylor series  $f(z) = \sum_{k=0}^{\infty} a_k(z - z_0)^k$  are  $a_k = f^{(k)}(z_0)/k!, k = 0, 1, 2, \dots$ , it follows from (4) that the first  $n$  terms series are zero, and so the expansion must have the form

$$f(z) = a_n(z - z_0)^n + a_{n+1}(z - z_0)^{n+1} + a_{n+2}(z - z_0)^{n+2} + \dots$$

$$= (z - z_0)^n [a_n + a_{n+1}(z - z_0) + a_{n+2}(z - z_0)^2 + \dots]$$

With the power-series identification

$$\phi(z) = a_n + a_{n+1}(z - z_0) + a_{n+2}(z - z_0)^2 + \dots$$

we conclude that  $\phi$  is an analytic function and that  $\phi(z_0) = a_n \neq 0$  because  $a_n = f^{(n)}(z_0)/n! \neq 0$  from (4).

$f(z_0) = 0$   
 $f^{(k)}(z_0) = 0 \quad |k| \leq n-1$   
 $f^{(n)}(z_0) \neq 0$

$f(z) = \frac{0}{0} + \frac{0}{1!}(z-z_0) + \dots$   
 $+ \frac{0}{(n-1)!}(z-z_0)^{n-1}$   
 $+ \frac{a_n}{n!}(z-z_0)^n$   
 $+ \dots$

We know  $a_k = \frac{f^{(k)}(z_0)}{k!}$

$f(z) = \frac{a_n}{n!}(z-z_0)^n + \dots$   
 $= (z-z_0)^n \left[ \frac{a_n}{n!} + \frac{a_{n+1}}{(n+1)!}(z-z_0) + \dots \right]$   
 $= (z-z_0)^n \phi(z)$   
 $\phi(z)$  is analytic &  $\phi(z_0) = a_n \neq 0$

### EXAMPLE 3 Order of a Zero

The analytic function  $f(z) = z \sin z^2$  has a zero at  $z = 0$ . If we replace  $z$  by  $z^2$  in (13) of Section 6.2, we obtain the Maclaurin expansion

$$\sin z^2 = z^2 - \frac{z^6}{3!} + \frac{z^{10}}{5!} - \dots$$

Then by factoring  $z^2$  out of the foregoing series we can rewrite  $f$  as

$$f(z) = z \sin z^2 = z^3 \phi(z) \quad \text{where} \quad \phi(z) = 1 - \frac{z^4}{3!} + \frac{z^8}{5!} - \dots \quad (6)$$

and  $\phi(0) = 1$ . When compared to (5), the result in (6) shows that  $z = 0$  is a zero of order 3 of  $f$ .

*Handwritten notes:*  
 $\text{tg } z = \frac{\sin z}{\cos z}$   
 $1 - \frac{z^2}{2!} + \frac{z^4}{4!} - \dots$   
 $z + \frac{z^3}{3!} + \dots$   
 Maclaurin Series of  $\text{tg } z$

### Poles

We can characterize a pole of order  $n$  in a manner analogous to (5).

#### Theorem 6.12 Pole of Order $n$

A function  $f$  analytic in a punctured disk  $0 < |z - z_0| < R$  has a pole of order  $n$  at  $z = z_0$  if and only if  $f$  can be written

$$f(z) = \frac{\phi(z)}{(z - z_0)^n}, \quad (7)$$

where  $\phi$  is analytic at  $z = z_0$  and  $\phi(z_0) \neq 0$ .

**Partial Proof** As in the proof of (5), we will establish the "only if" part of the preceding sentence. Since  $f$  is assumed to have a pole of order  $n$  at  $z_0$  it can be expanded in a Laurent series

$$f(z) = \frac{a_{-n}}{(z - z_0)^n} + \dots + \frac{a_{-2}}{(z - z_0)^2} + \frac{a_{-1}}{z - z_0} + a_0 + a_1(z - z_0) + \dots, \quad (8)$$

valid in some punctured disk  $0 < |z - z_0| < R$ . By factoring out  $1/(z - z_0)^n$ , (8) confirms that  $f$  can be written in the form  $\phi(z)/(z - z_0)^n$ . Here we identify

$$\phi(z) = a_{-n} + \dots + a_{-2}(z - z_0)^{n-2} + a_{-1}(z - z_0)^{n-1} + a_0(z - z_0)^n + a_1(z - z_0)^{n+1} + \dots, \quad (9)$$

as a power series valid for the open disk  $|z - z_0| < R$ . By assumption,  $z = z_0$  is a pole of order  $n$  of  $f$ , and so we must have  $a_{-n} \neq 0$ . If we define  $\phi(z_0) = a_{-n}$ , then it follows from (9) that  $\phi$  is analytic throughout the disk  $|z - z_0| < R$ .

*Handwritten notes:*  
 $f(z) = \frac{g(z)}{h(z)} = \frac{g(z_0) + g'(z_0)(z - z_0) + \frac{g''(z_0)}{2!}(z - z_0)^2 + \dots}{\frac{h^{(n)}(z_0)}{n!}(z - z_0)^n + \dots}$   
 $= \frac{g(z_0) + \dots}{h^{(n)}(z_0)} \cdot \frac{1}{(z - z_0)^n} + \dots$   
 we have a pole of order  $n$

#### Theorem 6.13 Pole of Order $n$

If the functions  $g$  and  $h$  are analytic at  $z = z_0$  and  $h$  has a zero of order  $n$  at  $z = z_0$  and  $g(z_0) \neq 0$ , then the function  $f(z) = g(z)/h(z)$  has a pole of order  $n$  at  $z = z_0$ .

### Theorem 6.13 Pole of Order $n$

If the functions  $g$  and  $h$  are analytic at  $z = z_0$  and  $h$  has a zero of order  $n$  at  $z = z_0$  and  $g(z_0) \neq 0$ , then the function  $f(z) = g(z)/h(z)$  has a pole of order  $n$  at  $z = z_0$ .

**Proof** Because the function  $h$  has zero of order  $n$ , (5) gives  $h(z) = (z - z_0)^n \phi(z)$ , where  $\phi$  is analytic at  $z = z_0$  and  $\phi(z_0) \neq 0$ . Thus  $f$  can be written

$$f(z) = \frac{g(z)/\phi(z)}{(z - z_0)^n}. \quad (10)$$

Since  $g$  and  $\phi$  are analytic at  $z = z_0$  and  $\phi(z_0) \neq 0$ , it follows that the function  $g/\phi$  is analytic at  $z_0$ . Moreover,  $g(z_0) \neq 0$  implies  $g(z_0)/\phi(z_0) \neq 0$ . We conclude from Theorem 6.12 that the function  $f$  has a pole of order  $n$  at  $z_0$ . 

When  $n = 1$  in (10), we see that a zero of order 1, or a simple zero, in the denominator  $h$  of  $f(z) = g(z)/h(z)$  corresponds to a simple pole of  $f$ .

### EXAMPLE 4 Order of Poles

(a) Inspection of the rational function

$$f(z) = \frac{2z + 5}{(z - 1)(z + 5)(z - 2)^4}$$

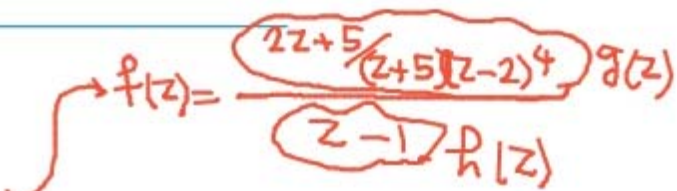

shows that the denominator has zeros of order 1 at  $z = 1$  and  $z = -5$ , and a zero of order 4 at  $z = 2$ . Since the numerator is not zero at any of these points, it follows from Theorem 6.13 and (10) that  $f$  has simple poles at  $z = 1$  and  $z = -5$ , and a pole of order 4 at  $z = 2$ .

(b) In Example 3 we saw that  $z = 0$  is a zero of order 3 of  $z \sin z^2$ . From Theorem 6.13 and (10) we conclude that the reciprocal function  $f(z) = 1/(z \sin z^2)$  has a pole of order 3 at  $z = 0$ .

### Remarks

- (i) From the preceding discussion, it should be intuitively clear that if a function  $f$  has a pole at  $z = z_0$ , then  $|f(z)| \rightarrow \infty$  as  $z \rightarrow z_0$  from any direction. From (i) of the Remarks following Section 2.6 we can write  $\lim_{z \rightarrow z_0} f(z) = \infty$ .
- (ii) If you peruse other texts on complex variables, and you are encouraged to do this, you may encounter the term *meromorphic*. A function  $f$  is **meromorphic** if it is analytic throughout a domain  $D$ , except possibly for poles in  $D$ . It can be proved that a meromorphic function can have at most a finite number of poles in  $D$ . For example, the rational function  $f(z) = 1/(z^2 + 1)$  is meromorphic in the complex plane.



## Residue

The coefficient  $a_{-1}$  of  $1/(z - z_0)$  in the Laurent series given above is called the **residue** of the function  $f$  at the isolated singularity  $z_0$ . We shall use the notation

$$a_{-1} = \text{Res}(f(z), z_0)$$

Res(f, z<sub>0</sub>)

$$f(z) = \frac{a_n}{(z-z_0)^n} + \dots + \frac{a_{-1}}{z-z_0} + a_0 + a_1(z-z_0) + \dots$$

### EXAMPLE 1 Residues

(a) In part (b) of Example 2 in Section 6.4 we saw that  $z = 1$  is a pole of order two of the function  $f(z) = \frac{1}{(z-1)^2(z-3)}$ . From the Laurent series obtained in that example valid for the deleted neighborhood of  $z = 1$  defined by  $0 < |z-1| < 2$ ,

$$f(z) = \frac{-1/2}{(z-1)^2} + \frac{\overbrace{-1/4}^{a_{-1}}}{z-1} - \frac{1}{8} - \frac{z-1}{16} - \dots$$

$\frac{1}{(z-1)^2} \cdot \frac{1}{1 - \underbrace{-(z-2)}_w}$

we see that the coefficient of  $1/(z-1)$  is  $a_{-1} = \text{Res}(f(z), 1) = -\frac{1}{4}$ .

(b) In Example 6 of Section 6.3 we saw that  $z = 0$  is an essential singularity of  $f(z) = e^{3/z}$ . Inspection of the Laurent series obtained in that example,

$$e^{3/z} = 1 + \frac{\overbrace{3}^{a_{-1}}}{z} + \frac{3^2}{2!z^2} + \frac{3^3}{3!z^3} + \dots,$$

$0 < |z| < \infty$ , shows that the coefficient of  $1/z$  is  $a_{-1} = \text{Res}(f(z), 0) = 3$ .

### Theorem 6.14 Residue at a Simple Pole

If  $f$  has a simple pole at  $z = z_0$ , then

$$\text{Res}(f(z), z_0) = \lim_{z \rightarrow z_0} (z - z_0)f(z) \tag{1}$$

$\frac{1}{(z-z_0)^{1-1}} \cdot \frac{d^{1-1}}{dz^{1-1}} (z-z_0)^1 f(z)$

**Proof** Since  $f$  has a simple pole at  $z = z_0$ , its Laurent expansion convergent on a punctured disk  $0 < |z - z_0| < R$  has the form

$$f(z) = \frac{a_{-1}}{z - z_0} + a_0 + a_1(z - z_0) + a_2(z - z_0)^2 + \dots, \rightarrow (z - z_0)^p f(z) = a_{-1} + a_0(z - z_0) + \dots$$

where  $a_{-1} \neq 0$ . By multiplying both sides of this series by  $z - z_0$  and then taking the limit as  $z \rightarrow z_0$  we obtain

$$\begin{aligned} \lim_{z \rightarrow z_0} (z - z_0)f(z) &= \lim_{z \rightarrow z_0} [a_{-1} + a_0(z - z_0) + a_1(z - z_0)^2 + \dots] \\ &= a_{-1} = \text{Res}(f(z), z_0). \end{aligned}$$

$\lim_{z \rightarrow z_0} (z - z_0)^p f(z) = \lim_{z \rightarrow z_0} \varphi(z) = \varphi(z_0) = a_{-1}$

an analytic function & so cts

### Theorem 6.15 Residue at a Pole of Order $n$

If  $f$  has a pole of order  $n$  at  $z = z_0$ , then

$$\text{Res}(f(z), z_0) = \frac{1}{(n-1)!} \lim_{z \rightarrow z_0} \frac{d^{n-1}}{dz^{n-1}} (z - z_0)^n f(z). \quad (2)$$

$n=1 \rightarrow \lim_{z \rightarrow z_0} (z - z_0) f(z)$



**Proof** Because  $f$  is assumed to have pole of order  $n$  at  $z = z_0$ , its Laurent expansion convergent on a punctured disk  $0 < |z - z_0| < R$  must have the form

$$f(z) = \frac{a_{-n}}{(z - z_0)^n} + \dots + \frac{a_{-2}}{(z - z_0)^2} + \frac{a_{-1}}{z - z_0} + a_0 + a_1(z - z_0) + \dots,$$

where  $a_{-n} \neq 0$ . We multiply the last expression by  $(z - z_0)^n$ ,

$(z - z_0)^n f(z) = a_{-n} + \dots + a_{-2}(z - z_0)^{n-2} + a_{-1}(z - z_0)^{n-1} + a_0(z - z_0)^n + a_1(z - z_0)^{n+1} + \dots$

So  $(z - z_0)^n f(z)$  has a removable singularity at  $z_0$ . So by putting  $\phi(z) = a_{-n}$  we get an analytic function at  $z_0$ . So  $a_{-1} = (n-1)! \phi'(z_0)$

$$\frac{d^{n-1}}{dz^{n-1}} (z - z_0)^n f(z) = (n-1)! a_{-1} + n! a_0 (z - z_0) + \dots \quad (3)$$

Since all the terms on the right-hand side after the first involve positive integer powers of  $z - z_0$ , the limit of (3) as  $z \rightarrow z_0$  is

$$\lim_{z \rightarrow z_0} \frac{d^{n-1}}{dz^{n-1}} (z - z_0)^n f(z) = (n-1)! a_{-1}.$$

Solving the last equation for  $a_{-1}$  gives (2).

Since  $\phi^{(n-1)}(z)$  is  $\lim_{z \rightarrow z_0} \frac{d^{n-1}}{dz^{n-1}} (z - z_0)^n f(z)$

### EXAMPLE 2 Residue at a Pole

The function  $f(z) = \frac{1}{(z-1)^2(z-3)}$  has a simple pole at  $z = 3$  and a pole of order 2 at  $z = 1$ . Use Theorems 6.14 and 6.15 to find the residues.

**Solution** Since  $z = 3$  is a simple pole, we use (1):

$$\text{Res}(f(z), 3) = \lim_{z \rightarrow 3} (z - 3) f(z) = \lim_{z \rightarrow 3} \frac{1}{(z - 1)^2} = \frac{1}{4}.$$

Now at the pole of order 2, the result in (2) gives

$$\begin{aligned} \text{Res}(f(z), 1) &= \frac{1}{1!} \lim_{z \rightarrow 1} \frac{d}{dz} (z - 1)^2 f(z) \\ &= \lim_{z \rightarrow 1} \frac{d}{dz} \frac{1}{z - 3} \\ &= \lim_{z \rightarrow 1} \frac{-1}{(z - 3)^2} = -\frac{1}{4}. \end{aligned}$$

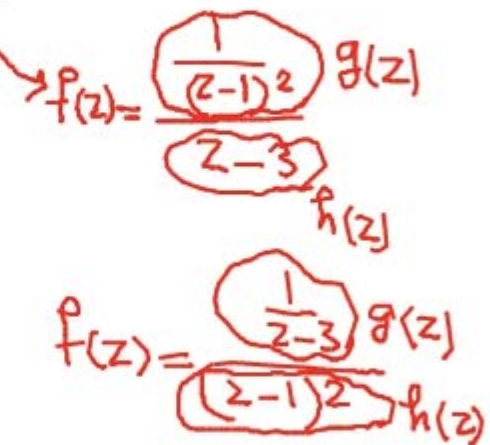

### Theorem 6.16 Cauchy's Residue Theorem

Let  $D$  be a simply connected domain and  $C$  a simple closed contour lying entirely within  $D$ . If a function  $f$  is analytic on and within  $C$ , except at a finite number of isolated singular points  $z_1, z_2, \dots, z_n$  within  $C$ , then

$$\oint_C f(z) dz = 2\pi i \sum_{k=1}^n \text{Res}(f(z), z_k). \quad (5)$$

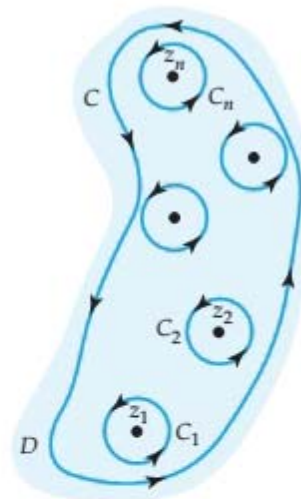

**Proof** Suppose  $C_1, C_2, \dots, C_n$  are circles centered at  $z_1, z_2, \dots, z_n$ , respectively. Suppose further that each circle  $C_k$  has a radius  $r_k$  small enough so that  $C_1, C_2, \dots, C_n$  are mutually disjoint and are interior to the simple closed curve  $C$ . See Figure 6.10. Now in (20) of Section 6.3 we saw that  $\oint_{C_k} f(z) dz = 2\pi i \text{Res}(f(z), z_k)$ , and so by Theorem 5.5 we have

$$\oint_C f(z) dz = \sum_{k=1}^n \oint_{C_k} f(z) dz = 2\pi i \sum_{k=1}^n \text{Res}(f(z), z_k) = \frac{1}{2\pi i} \int_C f(z) dz$$

#### EXAMPLE 4 Evaluation by the Residue Theorem

Evaluate  $\oint_C \frac{1}{(z-1)^2(z-3)} dz$ , where

- (a) the contour  $C$  is the rectangle defined by  $x = 0, x = 4, y = -1, y = 1$ ,  
 (b) and the contour  $C$  is the circle  $|z| = 2$ .

#### Solution

- (a) Since both  $z = 1$  and  $z = 3$  are poles within the rectangle we have from (5) that

$$\oint_C \frac{1}{(z-1)^2(z-3)} dz = 2\pi i [\text{Res}(f(z), 1) + \text{Res}(f(z), 3)]$$

We found these residues in Example 2. Therefore,

$$\oint_C \frac{1}{(z-1)^2(z-3)} dz = 2\pi i \left[ \left(-\frac{1}{4}\right) + \frac{1}{4} \right] = 0.$$

- (b) Since only the pole  $z = 1$  lies within the circle  $|z| = 2$ , we have from (5)

$$\oint_C \frac{1}{(z-1)^2(z-3)} dz = 2\pi i \text{Res}(f(z), 1) = 2\pi i \left(-\frac{1}{4}\right) = -\frac{\pi}{2}i.$$

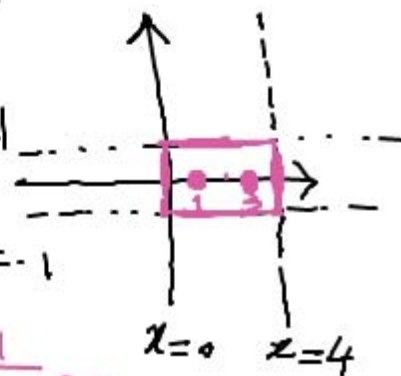

Handwritten notes for residue calculation:

$$\lim_{z \rightarrow 3} \frac{d}{dz} \left( (z-1)^2 f(z) \right) = \lim_{z \rightarrow 3} \frac{-1}{(z-3)^2} = \frac{-1}{4}$$

Handwritten note for residue calculation:

$$\lim_{z \rightarrow 3} \left[ (z-3) \cdot \frac{1}{(z-1)^2(z-3)} \right] = \frac{1}{4}$$

(c)  $\oint_C \frac{1}{(z-1)^2(z-3)} dz = 0$



Handwritten note:  $|z+1|=1$  the function is analytic on & within the circle  $|z+1|=1$

**EXAMPLE 5 Evaluation by the Residue Theorem**

Evaluate  $\oint_C \frac{2z+6}{z^2+4} dz$ , where the contour  $C$  is the circle  $|z-i|=2$ .

$z^2 = -4 \rightarrow z = \pm 2i$



**Solution** By factoring the denominator as  $z^2+4 = (z-2i)(z+2i)$  we see that the integrand has simple poles at  $-2i$  and  $2i$ . Because only  $2i$  lies within the contour  $C$ , it follows from (5) that

$$\oint_C \frac{2z+6}{z^2+4} dz = 2\pi i \operatorname{Res}(f(z), 2i).$$

$z = -4 = 4 \operatorname{cis} \pi$   
 $z = \sqrt[2]{4} \operatorname{cis} \frac{2k\pi + \pi}{2}$   
 $= \pm 2i$

But 
$$\operatorname{Res}(f(z), 2i) = \lim_{z \rightarrow 2i} (z-2i) \frac{2z+6}{(z-2i)(z+2i)}$$

$$= \frac{6+4i}{4i} = \frac{3+2i}{2i}.$$

Hence, 
$$\oint_C \frac{2z+6}{z^2+4} dz = 2\pi i \left( \frac{3+2i}{2i} \right) = \pi(3+2i).$$

**EXAMPLE 6 Evaluation by the Residue Theorem**

Evaluate  $\oint_C \frac{e^z}{z^4+5z^3} dz$ , where the contour  $C$  is the circle  $|z|=2$ .

$z=0, z=-5$

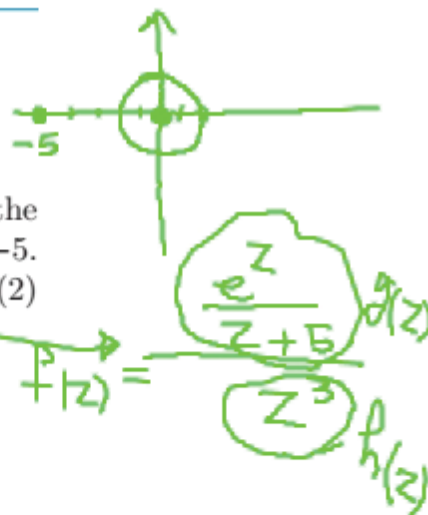

**Solution** Writing the denominator as  $z^4+5z^3 = z^3(z+5)$  reveals that the integrand  $f(z)$  has a pole of order 3 at  $z=0$  and a simple pole at  $z=-5$ . But only the pole  $z=0$  lies within the given contour and so from (5) and (2) we have,

$$\oint_C \frac{e^z}{z^4+5z^3} dz = 2\pi i \operatorname{Res}(f(z), 0) = 2\pi i \frac{1}{2!} \lim_{z \rightarrow 0} \frac{d^2}{dz^2} z^3 \cdot \frac{e^z}{z^3(z+5)}$$

$$= \pi i \lim_{z \rightarrow 0} \frac{(z^2+8z+17)e^z}{(z+5)^3} = \frac{17\pi}{125} i.$$

$1 + \frac{3}{z} + \frac{1}{2!} \left(\frac{3}{z}\right)^2 + \frac{1}{3!} \left(\frac{3}{z}\right)^3 + \dots$

**EXAMPLE 8 Evaluation by the Residue Theorem**

Evaluate  $\oint_C e^{3/z} dz$ , where the contour  $C$  is the circle  $|z|=1$ .

essential singularity at  $z=0$   
 $\operatorname{Res}(e^{3/z}, 0) = 3$

**Solution** As we have seen,  $z=0$  is an essential singularity of the integrand  $f(z) = e^{3/z}$  and so neither formulas (1) and (2) are applicable to find the residue of  $f$  at that point. Nevertheless, we saw in Example 1 that the Laurent series of  $f$  at  $z=0$  gives  $\operatorname{Res}(f(z), 0) = 3$ . Hence from (5) we have

$$\oint_C e^{3/z} dz = 2\pi i \operatorname{Res}(f(z), 0) = 2\pi i (3) = 6\pi i.$$

## Integrals of the Form $\int_0^{2\pi} F(\cos \theta, \sin \theta) d\theta$

The basic idea

here is to convert a real trigonometric integral of form (1) into a complex integral, where the contour  $C$  is the unit circle  $|z| = 1$  centered at the origin.

To do this we begin with (10) of Section 2.2 to parametrize this contour by

$$z = e^{i\theta}, \quad 0 \leq \theta \leq 2\pi$$

We can then write

$$dz = i e^{i\theta} d\theta, \quad \cos \theta = \frac{e^{i\theta} + e^{-i\theta}}{2}, \quad \sin \theta = \frac{e^{i\theta} - e^{-i\theta}}{2i}$$

The last two expressions follow from (2) and (3) of Section 4.3. Since  $dz = i e^{i\theta} d\theta = iz d\theta$  and  $z^{-1} = 1/z = e^{-i\theta}$ , these three quantities are equivalent to

$$d\theta = \frac{dz}{iz}, \quad \cos \theta = \frac{1}{2}(z + z^{-1}), \quad \sin \theta = \frac{1}{2i}(z - z^{-1}). \quad (4)$$

The conversion of the integral in (1) into a contour integral is accomplished by replacing, in turn,  $d\theta$ ,  $\cos \theta$ , and  $\sin \theta$  by the expressions in (4):

$$\oint_C F\left(\frac{1}{2}(z + z^{-1}), \frac{1}{2i}(z - z^{-1})\right) \frac{dz}{iz} = \int_0^{2\pi} F(\cos \theta, \sin \theta) d\theta$$

$z = e^{i\theta}$   
 $0 \leq \theta \leq 2\pi$

where  $C$  is the unit circle  $|z| = 1$ .

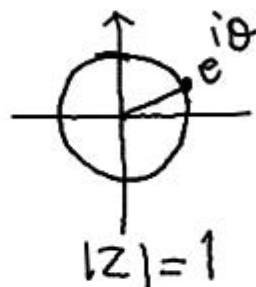

### EXAMPLE 1 A Real Trigonometric Integral

Evaluate  $\int_0^{2\pi} \frac{1}{(2 + \cos \theta)^2} d\theta = \frac{4\pi}{3\sqrt{3}}$ .

**Solution** When we use the substitutions given in (4), the given trigonometric integral becomes the contour integral

$$\oint_C \frac{1}{\left(2 + \frac{1}{2}(z + z^{-1})\right)^2} \frac{dz}{iz} = \oint_C \frac{1}{\left(2 + \frac{z^2 + 1}{2z}\right)^2} \frac{dz}{iz}$$

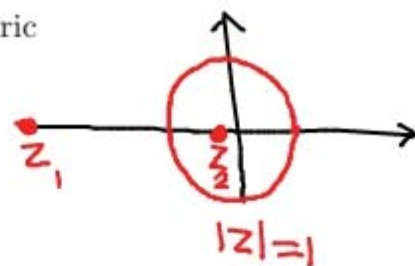

Carrying out the algebraic simplification of the integrand then yields

$$\frac{4}{i} \oint_C \frac{z}{(z^2 + 4z + 1)^2} dz \rightarrow z = \frac{-2 \pm \sqrt{4 - 1}}{1}$$

From the quadratic formula we can factor the polynomial  $z^2 + 4z + 1$  as  $z^2 + 4z + 1 = (z - z_1)(z - z_2)$ , where  $z_1 = -2 - \sqrt{3}$  and  $z_2 = -2 + \sqrt{3}$ . Thus, the integrand can be written

$$\frac{z}{(z^2 + 4z + 1)^2} = \frac{z}{(z - z_1)^2(z - z_2)^2}$$

Because only  $z_2$  is inside the unit circle  $C$ , we have

$$\oint_C \frac{z}{(z^2 + 4z + 1)^2} dz = 2\pi i \operatorname{Res}(f(z), z_2)$$

$$\frac{4}{i} \oint_C \frac{z}{(z^2 + 4z + 1)^2} dz = \frac{4}{i} \cdot 2\pi i \operatorname{Res}(f(z), z_1) = \frac{4}{i} \cdot 2\pi i \cdot \frac{1}{6\sqrt{3}}$$

To calculate the residue, we first note that  $z_2$  is a pole of order 2 and so we use (2) of Section 6.5:

$$\operatorname{Res}(f(z), z_2) = \lim_{z \rightarrow z_2} \frac{d}{dz} (z - z_2)^2 f(z) = \lim_{z \rightarrow z_2} \frac{d}{dz} \frac{z}{(z - z_1)^2} = \lim_{z \rightarrow z_2} \frac{-z - z_1}{(z - z_1)^3} = \frac{1}{6\sqrt{3}}$$

# Integrals of the Form $\int_{-\infty}^{\infty} f(x) dx$

Suppose  $y = f(x)$  is a real function that is defined and continuous on the interval  $[0, \infty)$ . In elementary calculus the improper integral  $I_1 = \int_0^{\infty} f(x) dx$  is defined as the limit

*improper integral*  $I_1 = \int_0^{\infty} f(x) dx \stackrel{\text{def}}{=} \lim_{R \rightarrow \infty} \int_0^R f(x) dx \in \mathbb{R}$  (5)



If the limit exists, the integral  $I_1$  is said to be **convergent**; otherwise, it is **divergent**. The improper integral  $I_2 = \int_{-\infty}^0 f(x) dx$  is defined similarly:

$$I_2 = \int_{-\infty}^0 f(x) dx = \lim_{R \rightarrow \infty} \int_{-R}^0 f(x) dx. \quad (6)$$

$\lim_{x \rightarrow 0} \frac{1}{x^2} = +\infty$   
The limit exists but its value is infinite.

Finally, if  $f$  is continuous on  $(-\infty, \infty)$ , then  $\int_{-\infty}^{\infty} f(x) dx$  is defined to be

$$\int_{-\infty}^{\infty} f(x) dx = \int_{-\infty}^0 f(x) dx + \int_0^{\infty} f(x) dx = I_1 + I_2, \quad (7)$$

$\lim_{x \rightarrow 0} \sin \frac{1}{x}$  does not exist.

provided both integrals  $I_1$  and  $I_2$  are convergent. If either one,  $I_1$  or  $I_2$ , is divergent, then  $\int_{-\infty}^{\infty} f(x) dx$  is divergent. It is important to remember that the right-hand side of (7) is *not* the same as

$$\lim_{R \rightarrow \infty} \left[ \int_{-R}^0 f(x) dx + \int_0^R f(x) dx \right] = \lim_{R \rightarrow \infty} \int_{-R}^R f(x) dx. \quad (8)$$

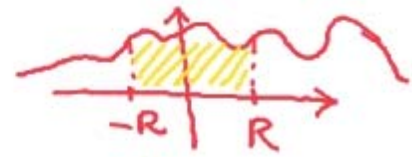

For the integral  $\int_{-\infty}^{\infty} f(x) dx$  to be convergent, the limits (5) and (6) must exist independently of one another. *But*, in the event that we know (a priori) that an improper integral  $\int_{-\infty}^{\infty} f(x) dx$  converges, we can then evaluate it by means of the single limiting process given in (8):

$$\int_{-\infty}^{\infty} f(x) dx = \lim_{R \rightarrow \infty} \int_{-R}^R f(x) dx.$$

$$\lim_{R \rightarrow \infty} \int_{-R}^R f(x) dx = \lim_{R \rightarrow \infty} \int_{-R}^0 f(x) dx + \lim_{R \rightarrow \infty} \int_0^R f(x) dx$$

On the other hand, the symmetric limit in (9) may exist even though the improper integral  $\int_{-\infty}^{\infty} f(x) dx$  is divergent. For example, the integral  $\int_{-\infty}^{\infty} x dx$  is divergent since  $\lim_{R \rightarrow \infty} \int_0^R x dx = \lim_{R \rightarrow \infty} \frac{1}{2} R^2 = \infty$ . However, (9) gives

$$\lim_{R \rightarrow \infty} \int_{-R}^R f(x) dx = \lim_{R \rightarrow \infty} \frac{R^2}{2} = \infty$$

So  $\int_{-\infty}^{\infty} f(x) dx$  is divergent and so is  $\int_{-\infty}^{\infty} f(x) dx$

$$\lim_{R \rightarrow \infty} \int_{-R}^R x dx = \lim_{R \rightarrow \infty} \frac{1}{2} [R^2 - (-R)^2] = 0. \quad (10)$$

The limit in (9), if it exists, is called the **Cauchy principal value** (P.V.) of the integral and is written

$$\text{P.V.} \int_{-\infty}^{\infty} f(x) dx = \lim_{R \rightarrow \infty} \int_{-R}^R f(x) dx.$$

In (10) we have shown that  $\text{P.V.} \int_{-\infty}^{\infty} x dx = 0$ . To summarize:

Assume that  $\int_{-\infty}^{\infty} f(x) dx$  is convergent.  $\int_{-\infty}^{\infty} f(x) dx = \int_{-\infty}^0 f(x) dx + \int_0^{\infty} f(x) dx$  are conv.

$$\lim_{R \rightarrow \infty} \int_{-R}^R f(x) dx = \lim_{R \rightarrow \infty} \left[ \int_{-R}^0 f(x) dx + \int_0^R f(x) dx \right] = \lim_{R \rightarrow \infty} \int_{-R}^0 f(x) dx + \lim_{R \rightarrow \infty} \int_0^R f(x) dx = \int_{-\infty}^0 f(x) dx + \int_0^{\infty} f(x) dx = \int_{-\infty}^{\infty} f(x) dx$$

## Cauchy Principal Value

When an integral of form (2) converges, its Cauchy principal value is the same as the value of the integral. If the integral diverges, it may still possess a Cauchy principal value (11).

One final point about the Cauchy principal value: Suppose  $f(x)$  is continuous on  $(-\infty, \infty)$  and is an *even* function, that is,  $f(-x) = f(x)$ . Then its graph is symmetric with respect to the  $y$ -axis and as a consequence

$$\int_{-R}^0 f(x) dx = \int_0^R f(x) dx \quad (12)$$

and 
$$\int_{-R}^R f(x) dx = \int_{-R}^0 f(x) dx + \int_0^R f(x) dx = 2 \int_0^R f(x) dx. \quad (13)$$

From (12) and (13) we conclude that if the Cauchy principal value (11) exists, then both  $\int_0^\infty f(x) dx$  and  $\int_{-\infty}^0 f(x) dx$  converge. The values of the integrals are

$$\int_0^\infty f(x) dx = \frac{1}{2} \text{P.V.} \int_{-\infty}^\infty f(x) dx \quad \text{and} \quad \int_{-\infty}^0 f(x) dx = \text{P.V.} \int_{-\infty}^\infty f(x) dx.$$

To evaluate an integral  $\int_{-\infty}^\infty f(x) dx$ , where the rational function  $f(x) = p(x)/q(x)$  is continuous on  $(-\infty, \infty)$ , by residue theory we replace  $x$  by the complex variable  $z$  and integrate the complex function  $f$  over a closed contour  $C$  that consists of the interval  $[-R, R]$  on the real axis and a semicircle  $C_R$  of radius large enough to enclose all the poles of  $f(z) = p(z)/q(z)$  in the upper half-plane  $\text{Im}(z) > 0$ . See Figure 6.11. By Theorem 6.16 of Section 6.5 we have

$$\oint_C f(z) dz = \int_{C_R} f(z) dz + \int_{-R}^R f(x) dx = 2\pi i \sum_{k=1}^n \text{Res}(f(z), z_k),$$

where  $z_k, k = 1, 2, \dots, n$  denotes poles in the upper half-plane. If we can show that the integral  $\int_{C_R} f(z) dz \rightarrow 0$  as  $R \rightarrow \infty$ , then we have

$$\text{P.V.} \int_{-\infty}^\infty f(x) dx = \lim_{R \rightarrow \infty} \int_{-R}^R f(x) dx = 2\pi i \sum_{k=1}^n \text{Res}(f(z), z_k). \quad (14)$$

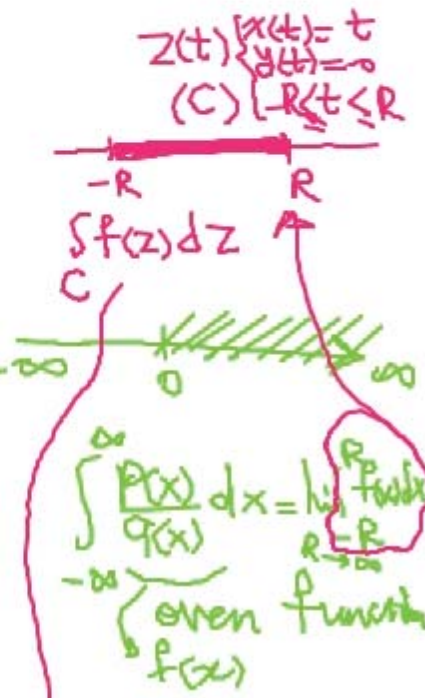
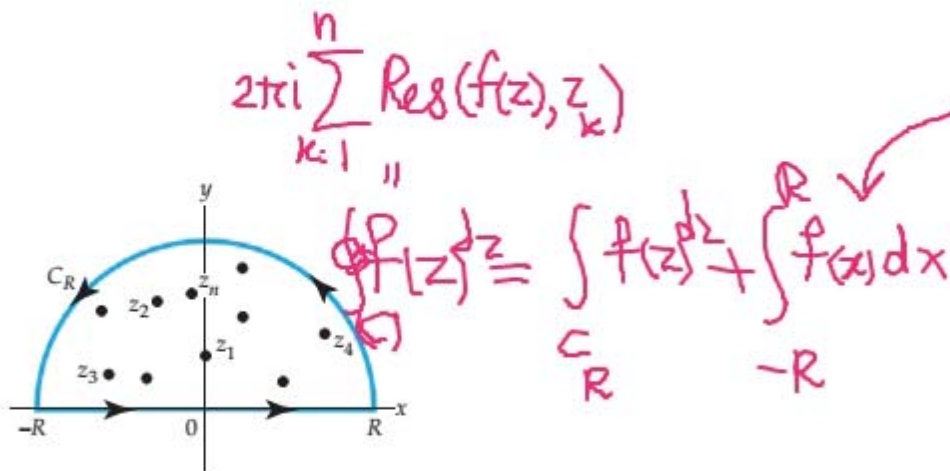

**EXAMPLE 2** Cauchy P.V. of an Improper Integral

Evaluate the Cauchy principal value of  $\int_{-\infty}^{\infty} \frac{1}{(x^2+1)(x^2+9)} dx$ .

**Solution** Let  $f(z) = 1/(z^2+1)(z^2+9)$ . Since

$$(z^2+1)(z^2+9) = (z-i)(z+i)(z-3i)(z+3i),$$

we take  $C$  be the closed contour consisting of the interval  $[-R, R]$  on the  $x$ -axis and the semicircle  $C_R$  of radius  $R > 3$ . As seen from Figure 6.12,

$$\oint_C \frac{1}{(z^2+1)(z^2+9)} dz = \int_{-R}^R \frac{1}{(x^2+1)(x^2+9)} dx + \int_{C_R} \frac{1}{(z^2+1)(z^2+9)} dz$$

$$= I_1 + I_2$$

and  $I_1 + I_2 = 2\pi i [\text{Res}(f(z), i) + \text{Res}(f(z), 3i)]$ .

At the simple poles  $z = i$  and  $z = 3i$  we find, respectively,

$$\text{Res}(f(z), i) = \frac{1}{16i} \quad \text{and} \quad \text{Res}(f(z), 3i) = -\frac{1}{48i},$$

$|z_1 - z_2| \leq |z_1 \pm z_2|$

so that  $I_1 + I_2 = 2\pi i \left[ \frac{1}{16i} + \left( -\frac{1}{48i} \right) \right] = \frac{\pi}{12}$ . (15)

We now want to let  $R \rightarrow \infty$  in (15). Before doing this, we use the inequality (10) of Section 1.2 to note that on the contour  $C_R$ ,

$$|(z^2+1)(z^2+9)| = |z^2+1| \cdot |z^2+9| \geq \underbrace{|z^2| - 1}_{|z|^2} \cdot \underbrace{|z^2| - 9}_{|z|^2} = (R^2 - 1)(R^2 - 9).$$

Since the length  $L$  of the semicircle is  $\pi R$ , it follows from the  $ML$ -inequality, Theorem 5.3 of Section 5.2, that

$$|I_2| = \left| \int_{C_R} \frac{1}{(z^2+1)(z^2+9)} dz \right| \leq \frac{\pi R}{(R^2-1)(R^2-9)}.$$

This last result shows that  $|I_2| \rightarrow 0$  as  $R \rightarrow \infty$ , and so we conclude that  $\lim_{R \rightarrow \infty} I_2 = 0$ . It follows from (15) that  $\lim_{R \rightarrow \infty} I_1 = \pi/12$ ; in other words,

$$\lim_{R \rightarrow \infty} \int_{-R}^R \frac{1}{(x^2+1)(x^2+9)} dx = \frac{\pi}{12} \quad \text{or P.V.} \int_{-\infty}^{\infty} \frac{1}{(x^2+1)(x^2+9)} dx = \frac{\pi}{12}.$$

$0 \leq a_n \leq b_n \Rightarrow \sum a_n < \infty$   
 $\sum b_n < \infty$   
 $\lim_{n \rightarrow \infty} \frac{a_n}{b_n} = L > 0 \Rightarrow \sum a_n < \infty$   
 $a_n \geq 0, b_n > 0, \sum b_n < \infty$   
 $\frac{a_n}{b_n} \leq L \Rightarrow a_n \leq L b_n$   
 Similar to conv. tests for series we have conv. test for proper integrals  
 $\lim_{x \rightarrow \infty} \frac{1}{(x^2+1)(x^2+9)} = 1/x^4 > 0$   
 since  $\int_0^{\infty} \frac{dx}{x^4} < \infty$ ,  
 so  $\int_0^{\infty} \frac{dx}{(x^2+1)(x^2+9)}$  (converges!)

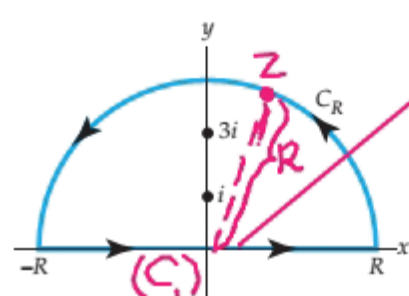

$x(t) = t$   
 $z(t) = 0$   
 $R \leq t \leq R$   
 $\int_{C_1} f(z) dz = \int_{-R}^R f(t+0i) \cdot \frac{1}{z'(t)} dt$

the length of  $C$   
 $\int_C f(z) dz \leq ML$   
 $\downarrow$   
 an upper bound for  $f(z)$  when  $z \in C$



# Integrals of the Form $\int_{-\infty}^{\infty} f(x) \cos \alpha x dx$ and

## $\int_{-\infty}^{\infty} f(x) \sin \alpha x dx$

Because improper integrals of the form

$\int_{-\infty}^{\infty} f(x) \sin \alpha x dx$  are encountered in applications of Fourier analysis, they often are referred to as **Fourier integrals**. Fourier integrals appear as the real and imaginary parts in the improper integral  $\int_{-\infty}^{\infty} f(x)e^{i\alpha x} dx$ .<sup>†</sup> In view

### EXAMPLE 4 Using Symmetry

Evaluate the Cauchy principal value of  $\int_0^{\infty} \frac{x \sin x}{x^2 + 9} dx$ .

**Solution** First note that the limits of integration in the given integral are not from  $-\infty$  to  $\infty$  as required by the method just described. This can be remedied by observing that since the integrand is an even function of  $x$  (verify), we can write

$$\int_0^{\infty} \frac{\sin x}{x^2 + 9} dx = \frac{1}{2} \int_{-\infty}^{\infty} \frac{\sin x}{x^2 + 9} dx.$$

With  $\alpha = 1$  we now form the contour integral

$$\oint_C \frac{e^{iz}}{z^2 + 9} dz,$$

where  $C$  is the same contour shown in Figure 6.12. By Theorem 6.16,

$$\int_{C_R} \frac{e^{iz}}{z^2 + 9} dz + \int_{-R}^R \frac{e^{ix}}{x^2 + 9} dx = 2\pi i \operatorname{Res}(f(z)e^{iz}, 3i),$$

where  $f(z) = 1/(z^2 + 9)$ , and

$$\operatorname{Res}(f(z)e^{iz}, 3i) = \left. \frac{e^{iz}}{2z} \right|_{z=3i} = \frac{e^{-3}}{6i}$$

from (4) of Section 6.5. Then, from Theorem 6.18 we conclude  $\int_{C_R} f(z)e^{iz} dz \rightarrow 0$  as  $R \rightarrow \infty$ , and so

$$\text{P.V.} \int_{-\infty}^{\infty} \frac{e^{ix}}{x^2 + 9} dx = 2\pi i \left( \frac{e^{-3}}{6i} \right) = \frac{\pi}{3e^3}.$$

But by (16),

$$\int_{-\infty}^{\infty} \frac{e^{ix}}{x^2 + 9} dx = \int_{-\infty}^{\infty} \frac{\cos x}{x^2 + 9} dx + i \int_{-\infty}^{\infty} \frac{\sin x}{x^2 + 9} dx = \frac{\pi}{3e^3} i.$$

Equating real and imaginary parts in the last line gives the bonus result

$$\text{P.V.} \int_{-\infty}^{\infty} \frac{\cos x}{x^2 + 9} dx = \frac{\pi}{3e^3} \text{ along with } \text{P.V.} \int_{-\infty}^{\infty} \frac{\sin x}{x^2 + 9} dx = \frac{\pi}{3e^3}.$$

Finally, in view of the fact that the integrand is an even function, we obtain the value of the prescribed integral:

$$\int_0^{\infty} \frac{x \sin x}{x^2 + 9} dx = \frac{1}{2} \int_{-\infty}^{\infty} \frac{x \sin x}{x^2 + 9} dx = \frac{\pi}{2e^3}.$$

$$e^{ix} = \cos x + i \sin x$$

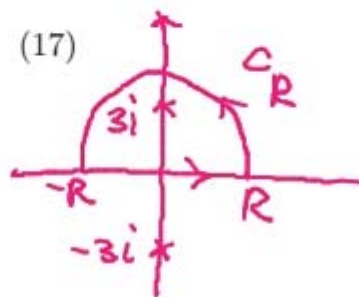

$\lim_{z \rightarrow z_0} (z - z_0)^p f(z) = \operatorname{Res}(f, z_0)$   
 $z \rightarrow z_0$   
 simple pole

$$\left| \frac{e^{iz}}{z^2 + 9} \right| \leq \frac{|e^{iz}|}{|z|^2 - 9}$$

$$= \frac{e^{-y}}{R^2 - 9} \leq \frac{1}{R^2 - 9}$$

$$\left| \int_{C_R} \frac{ze^{iz}}{z^2 + 9} dz \right| \leq \frac{\pi R}{R^2 - 9}$$

~~scribbles~~

$$\text{P.V.} \int_{-\infty}^{\infty} \frac{x \cos x}{x^2 + 9} dx = 0$$

$$\text{P.V.} \int_{-\infty}^{\infty} \frac{x \sin x}{x^2 + 9} dx = \frac{\pi}{e^3}.$$

### Theorem 6.19 Behavior of Integral as $r \rightarrow 0$

Suppose  $f$  has a simple pole  $z = c$  on the real axis. If  $C_r$  is the contour defined by  $z = c + re^{i\theta}$ ,  $0 \leq \theta \leq \pi$ , then

$$\lim_{r \rightarrow 0} \int_{C_r} f(z) dz = \pi i \operatorname{Res}(f(z), c).$$

**Proof** Since  $f$  has a simple pole at  $z = c$ , its Laurent series is

$$f(z) = \frac{a_{-1}}{z - c} + g(z),$$

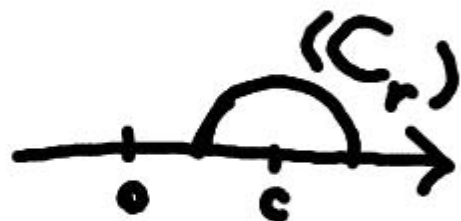

where  $a_{-1} = \operatorname{Res}(f(z), c)$  and  $g$  is analytic at the point  $c$ . Using the Laurent series and the parametrization of  $C_r$  we have

$$\int_{C_r} f(z) dz = a_{-1} \int_0^\pi \frac{ire^{i\theta}}{re^{i\theta}} d\theta + ir \int_0^\pi \underbrace{g(c + re^{i\theta})}_{z(\theta)} \underbrace{e^{i\theta} d\theta}_{z'(\theta)} = I_1 + I_2. \quad (19)$$

First, we see that

$$I_1 = a_{-1} \int_0^\pi \frac{ire^{i\theta}}{re^{i\theta}} d\theta = a_{-1} \int_0^\pi i d\theta = \pi i a_{-1} = \pi i \operatorname{Res}(f(z), c).$$

Next,  $g$  is analytic at  $c$ , and so it is continuous at this point and bounded in a neighborhood of the point; that is, there exists an  $M > 0$  for which  $|g(c + re^{i\theta})| \leq M$ . Hence,

$$|I_2| = \left| ir \int_0^\pi g(c + re^{i\theta}) d\theta \right| \leq r \int_0^\pi M d\theta = \pi r M.$$

$$\left| \int f(\theta) d\theta \right| \leq \int |f(\theta)| d\theta$$

It follows from this last inequality that  $\lim_{r \rightarrow 0} |I_2| = 0$  and consequently  $\lim_{r \rightarrow 0} I_2 = 0$ . By taking the limit of (19) as  $r \rightarrow 0$ , the theorem is proved. 

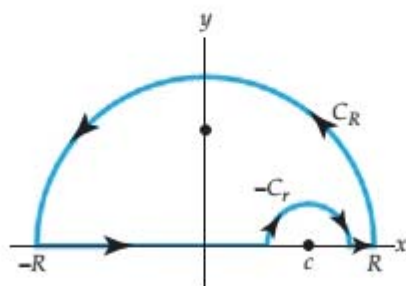

Figure 6.13 Indented contour

**EXAMPLE 5 Using an Indented Contour**

Evaluate the Cauchy principal value of  $\int_{-\infty}^{\infty} \frac{\sin x}{x(x^2 - 2x + 2)} dx$ .

**Solution** Since the integral is of the type given in (3), we consider the contour integral

$$\oint_C \frac{e^{iz}}{z(z^2 - 2z + 2)} dz.$$

The function  $f(z) = 1/(z^2 - 2z + 2)$  has a pole at  $z = 0$  and at  $z = 1 + i$  in the upper half-plane. The contour  $C$ , shown in Figure 6.14, is indented at the origin. Adopting an obvious condensed notation, we have

$$\oint_C = \int_{C_R} + \int_{-R}^{-r} + \int_{-C_r} + \int_r^R = 2\pi i \operatorname{Res}(f(z)e^{iz}, 1 + i), \quad (20)$$

where  $\int_{-C_r} = -\int_{C_r}$ . If we take the limits of (20) as  $R \rightarrow \infty$  and as  $r \rightarrow 0$ , it follows from Theorems 6.18 and 6.19 that

$$\text{P.V.} \int_{-\infty}^{\infty} \frac{e^{ix}}{x(x^2 - 2x + 2)} dx - \pi i \operatorname{Res}(f(z)e^{iz}, 0) = 2\pi i \operatorname{Res}(f(z)e^{iz}, 1 + i).$$

Now,

$$\operatorname{Res}(f(z)e^{iz}, 0) = \frac{1}{2} \quad \text{and} \quad \operatorname{Res}(f(z)e^{iz}, 1 + i) = -\frac{e^{-1+i}}{4} (1 + i).$$

Therefore,

$$\text{P.V.} \int_{-\infty}^{\infty} \frac{e^{ix}}{x(x^2 - 2x + 2)} dx = \pi i \left( \frac{1}{2} \right) + 2\pi i \left( -\frac{e^{-1+i}}{4} (1 + i) \right).$$

Using  $e^{-1+i} = e^{-1}(\cos 1 + i \sin 1)$ , simplifying, and then equating real and imaginary parts, we get from the last equality

$$\text{P.V.} \int_{-\infty}^{\infty} \frac{\cos x}{x(x^2 - 2x + 2)} dx = \frac{\pi}{2} e^{-1} (\sin 1 + \cos 1)$$

and 
$$\text{P.V.} \int_{-\infty}^{\infty} \frac{\sin x}{x(x^2 - 2x + 2)} dx = \frac{\pi}{2} [1 + e^{-1} (\sin 1 - \cos 1)].$$

$\operatorname{Im}(e^{iz})$

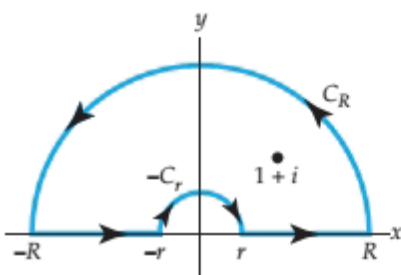
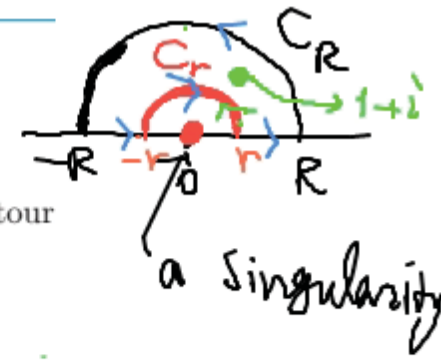

We will also use the term **conformal mapping** to refer to a complex mapping  $w = f(z)$  that is conformal at  $z_0$ . In addition, if  $w = f(z)$  maps a domain  $D$  onto a domain  $D'$  and if  $w = f(z)$  is conformal at every point in  $D$ , then we call  $w = f(z)$  a conformal mapping of  $D$  onto  $D'$ . From Section 2.3 it should be intuitively clear that if  $f(z) = az + b$  is a linear function with  $a \neq 0$ , then  $w = f(z)$  is conformal at every point in the complex plane. In Example 1 we have shown that the  $w = \bar{z}$  is not a conformal mapping at the point  $z_0 = 1 + i$  because the angles  $\theta$  and  $\phi$  are equal in magnitude but not in sense.

### Theorem 7.1 Conformal Mapping

If  $f$  is an analytic function in a domain  $D$  containing  $z_0$ , and if  $f'(z_0) \neq 0$ , then  $w = f(z)$  is a conformal mapping at  $z_0$ .

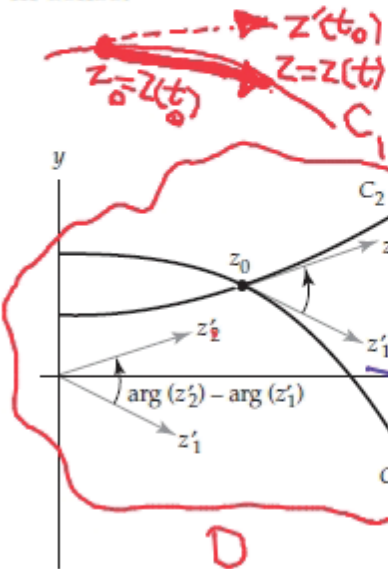

Handwritten red notes:  $z(t) - z(t_0) = z'(t_0)(t - t_0)$

Inspection of Figure 7.3 shows that the angle  $\theta$  between  $C_1$  and  $C_2$  at  $z_0$  is the value of

$$\arg(z'_2) - \arg(z'_1) \tag{1}$$

in the interval  $[0, \pi]$ , provided that we can rotate  $z'_1$  counterclockwise about  $z_0$  through the angle  $\theta$  onto  $z'_2$ . In the case that a clockwise rotation is needed, then  $-\theta$  is the value of (1) in the interval  $(-\pi, 0)$ . In either case, we see that (1) gives both the magnitude and sense of the angle between  $C_1$  and  $C_2$  at  $z_0$ .

**Proof** Suppose that  $f$  is analytic in a domain  $D$  containing  $z_0$ , and that  $f'(z_0) \neq 0$ . Let  $C_1$  and  $C_2$  be two smooth curves in  $D$  parametrized by  $z_1(t)$  and  $z_2(t)$ , respectively, with  $z_1(t_0) = z_2(t_0) = z_0$ . In addition, assume that  $w = f(z)$  maps the curves  $C_1$  and  $C_2$  onto the curves  $C'_1$  and  $C'_2$ . We wish to show that the angle  $\theta$  between  $C_1$  and  $C_2$  at  $z_0$  is equal to the angle  $\phi$  between  $C'_1$  and  $C'_2$  at  $f(z_0)$  in both magnitude and sense. We may assume, by renumbering  $C_1$  and  $C_2$  if necessary, that  $z'_1 = z'_1(t_0)$  can be rotated counterclockwise about  $z_0$  through the angle  $\theta$  onto  $z'_2 = z'_2(t_0)$ . Thus, by (1), the angle  $\theta$  is the unique value of  $\arg(z'_2) - \arg(z'_1)$  in the interval  $[0, \pi]$ . From (11) of Section 2.2,  $C'_1$  and  $C'_2$  are parametrized by  $w_1(t) = f(z_1(t))$  and  $w_2(t) = f(z_2(t))$ . In order to compute the tangent vectors  $w'_1$  and  $w'_2$  to  $C'_1$  and  $C'_2$  at  $f(z_0) = f(z_1(t_0)) = f(z_2(t_0))$  we use the chain rule

$$w'_1 = w'_1(t_0) = f'(z_1(t_0)) \cdot z'_1(t_0) = f'(z_0) \cdot z'_1,$$

and 
$$w'_2 = w'_2(t_0) = f'(z_2(t_0)) \cdot z'_2(t_0) = f'(z_0) \cdot z'_2.$$

Since  $C_1$  and  $C_2$  are smooth, both  $z'_1$  and  $z'_2$  are nonzero. Furthermore, by our hypothesis, we have  $f'(z_0) \neq 0$ . Therefore, both  $w'_1$  and  $w'_2$  are nonzero, and the angle  $\phi$  between  $C'_1$  and  $C'_2$  at  $f(z_0)$  is a value of

$$\arg(w'_2) - \arg(w'_1) = \arg(f'(z_0) \cdot z'_2) - \arg(f'(z_0) \cdot z'_1).$$

Now by two applications of (8) from Section 1.3 we obtain:

$$\begin{aligned} \arg(f'(z_0) \cdot z'_2) - \arg(f'(z_0) \cdot z'_1) &= \arg(f'(z_0)) + \arg(z'_2) - [\arg(f'(z_0)) + \arg(z'_1)] \\ &= \arg(z'_2) - \arg(z'_1). \end{aligned}$$

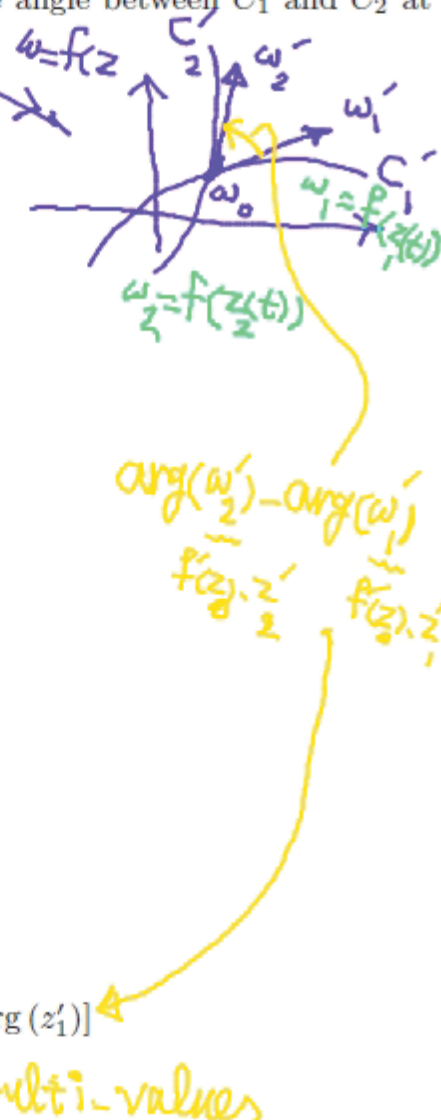

This expression has a unique value in  $[0, \pi]$ , namely  $\theta$ . Therefore,  $\theta = \phi$

Handwritten yellow note: multi-values

## EXAMPLE 2 Conformal Mappings

- (a) By Theorem 7.1 the entire function  $f(z) = e^z$  is conformal at every point in the complex plane since  $f'(z) = e^z \neq 0$  for all  $z$  in  $\mathbb{C}$ .
- (b) By Theorem 7.1 the entire function  $g(z) = z^2$  is conformal at all points  $z$ ,  $z \neq 0$ , since  $g'(z) = 2z \neq 0$ .

$$\begin{aligned} e^z &\neq 0 \quad \forall z \\ &\uparrow \\ |e^z| &= |e^x \operatorname{cis} y| \\ &\quad \text{Cof + iSine} \\ &= e^x \neq 0 \\ &\quad \forall x \end{aligned}$$

**Critical Points** The function  $g(z) = z^2$  in part (b) of Example 2 is not a conformal mapping at  $z_0 = 0$ . The reason for this is that  $g'(0) = 0$ . In general, if a complex function  $f$  is analytic at a point  $z_0$  and if  $f'(z_0) = 0$ , then  $z_0$  is called a **critical point** of  $f$ . Although it does not follow from Theorem 7.1, it is true that analytic functions are not conformal at critical points. More specifically, we can show that the following magnification of angles occurs at a critical point.

### Theorem 7.2 Angle Magnification at a Critical Point

Let  $f$  be analytic at the critical point  $z_0$ . If  $n > 1$  is an integer such that  $f'(z_0) = f''(z_0) = \dots = f^{(n-1)}(z_0) = 0$  and  $f^{(n)}(z_0) \neq 0$ , then the angle between any two smooth curves intersecting at  $z_0$  is increased by a factor of  $n$  by the complex mapping  $w = f(z)$ . In particular,  $w = f(z)$  is not a conformal mapping at  $z_0$ .

## EXAMPLE 3 Conformal Mappings

Find all points where the mapping  $f(z) = \sin z$  is conformal.

**Solution** The function  $f(z) = \sin z$  is entire, and from Section 4.3 we have that  $f'(z) = \cos z$ . In (21) of Section 4.3 we found that  $\cos z = 0$  if and only if  $z = (2n + 1)\pi/2$ ,  $n = 0, \pm 1, \pm 2, \dots$ , and so each of these points is a critical point of  $f$ . Therefore, by Theorem 7.1,  $w = \sin z$  is a conformal mapping at  $z$  for all  $z \neq (2n + 1)\pi/2$ ,  $n = 0, \pm 1, \pm 2, \dots$ . Furthermore, by Theorem 7.2,  $w = \sin z$  is not a conformal mapping at  $z$  if  $z = (2n + 1)\pi/2$ ,  $n = 0, \pm 1, \pm 2, \dots$ . Because  $f''(z) = -\sin z = \pm 1$  at the critical points of  $f$ , Theorem 7.2 also indicates that angles at these points are increased by a factor of 2.

$$\begin{aligned} \cos z &= \frac{e^{iz} + e^{-iz}}{2} = 0 \\ \omega^2 + 1 &= 0 \\ \omega &= \pm i \\ e^{i \operatorname{cis} x} &= e^{i(\pi/2 + 2\pi n)} = \operatorname{cis} \frac{\pi}{2} \\ &= \operatorname{cis} \frac{\pi}{2} \\ y=0 &\ \& \ x=2n\pi + \frac{\pi}{2} \end{aligned}$$

## Definition 7.2 Linear Fractional Transformation

If  $a, b, c,$  and  $d$  are complex constants with  $ad - bc \neq 0$ , then the complex function defined by:

$$T(z) = \frac{az + b}{cz + d} = \frac{p(z)}{q(z)} \quad (1)$$

My Tel: 072-3410390

is called a linear fractional transformation

$T(z) = \frac{a}{c}z + \frac{b}{c} - \frac{d}{c} \cdot \frac{1}{z + d/c}$   
 $\frac{1}{z + d/c} = \frac{1}{z - (-d/c)}$   
 $\frac{1}{z - (-d/c)} = \frac{1}{z - (-d/c)}$   
 we assume this

Linear fractional transformations are also called Möbius transformations or bilinear transformations. If  $c = 0$ , then the transformation  $T$  given by (1) is a linear mapping, and so a linear mapping is a special case of a linear fractional transformation. If  $c \neq 0$ , then we can write

$$T(z) = \frac{az + b}{cz + d} = \frac{bc - ad}{c} \frac{1}{cz + d} + \frac{a}{c} \quad (2)$$

$z = \frac{1}{\frac{1}{cz+d}}$

Setting  $A = \frac{bc - ad}{c}$  and  $B = \frac{a}{c}$ , we see that the linear transformation  $T$  in (2) can be written as the composition  $T(z) = f \circ g \circ h(z)$ , where  $f(z) = Az + B$  and  $h(z) = cz + d$  are linear functions and  $g(z) = 1/z$  is the reciprocal function.

The domain of a linear fractional transformation  $T$  given by (1) is the set of all complex  $z$  such that  $z \neq -d/c$ . Furthermore, since

$$T'(z) = \frac{ad - bc}{(cz + d)^2}$$

it follows from Theorem 7.1 and the requirement that  $ad - bc \neq 0$  that linear fractional transformations are conformal on their domains. The requirement that  $ad - bc \neq 0$  also ensures that the  $T$  is a one-to-one function on its domain. See Problem 27 in Exercises 7.2.

Observe that if  $c \neq 0$ , then (1) can be written as

$$T(z) = \frac{az + b}{cz + d} = \frac{(a/c)(z + b/a)}{z + d/c} = \frac{\phi(z)}{z - (-d/c)},$$

where  $\phi(z) = (a/c)(z + b/a)$ . Because  $ad - bc \neq 0$ , we have that  $\phi(-d/c) \neq 0$ , and so from Theorem 6.12 of Section 6.4 it follows that the point  $z = -d/c$  is a simple pole of  $T$ .

When  $c \neq 0$ , that is, when  $T$  is not a linear function, it is often helpful to view  $T$  as a mapping of the extended complex plane. Since  $T$  is defined for all points in the extended plane except the pole  $z = -d/c$  and the ideal point  $\infty$ , we need only extend the definition of  $T$  to include these points. We make this definition by considering the limit of  $T$  as  $z$  tends to the pole and as  $z$  tends to the ideal point. Because

$$\lim_{z \rightarrow -d/c} \frac{cz + d}{az + b} = \frac{0}{a(-d/c) + b} = \frac{0}{-ad + bc} = 0,$$

it follows from (25) of Section 2.6 that

$$\lim_{z \rightarrow -d/c} \frac{az + b}{cz + d} = \infty.$$

Moreover, from (24) of Section 2.6 we have that

$$\lim_{z \rightarrow \infty} \frac{az + b}{cz + d} = \lim_{z \rightarrow 0} \frac{a/z + b}{c/z + d} = \lim_{z \rightarrow 0} \frac{a + zb}{c + zd} = \frac{a}{c}.$$

11 March  
 10:00-11:00  
 my office  
 F21-512  
 Any question  
 maslehian@yahoo.com

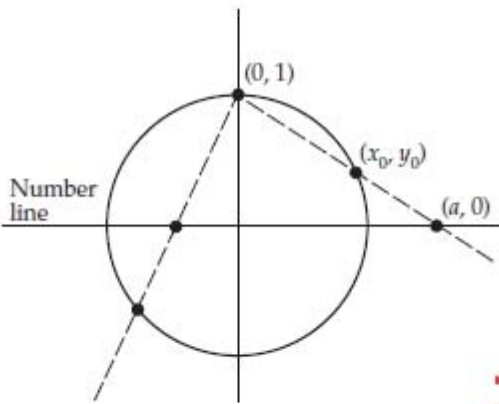

(a) Unit circle

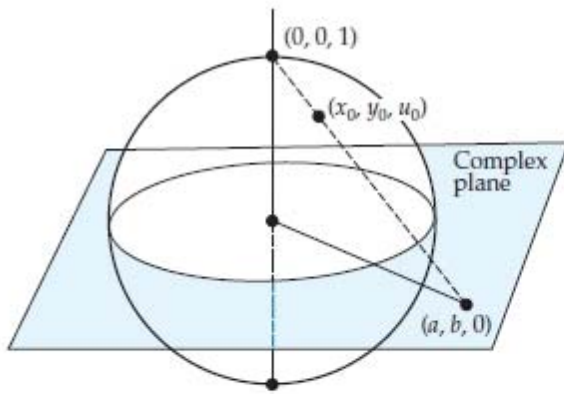

(b) Unit sphere

Metric Spaces:



$$d: X \times X \rightarrow \mathbb{R}$$

$$d(x, y) = 0 \iff x = y$$

$$d(x, y) \leq d(x, z) + d(z, y)$$

$$d(x, y) = d(y, x)$$

A metric space is a nonempty set  $X$  equipped with a mapping  $d: X \times X \rightarrow \mathbb{R}$  satisfying the above condition

Exercise:  $\forall x, y; d(x, y) \geq 0$

Solution:  $0 = d(x, x) \leq d(x, y) + d(y, x) = 2d(x, y)$

Examples

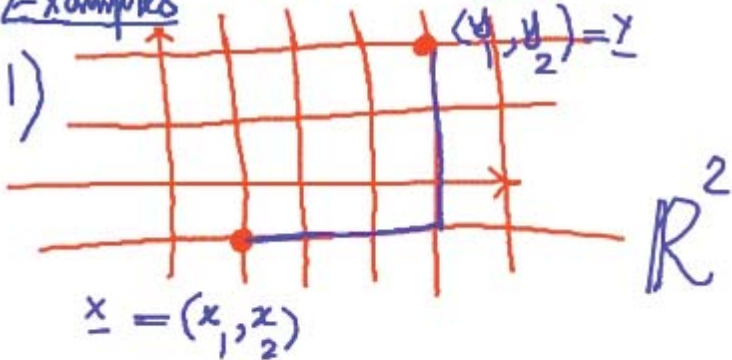

$$d_p(x, y) = |x_1 - y_1| + |x_2 - y_2|$$

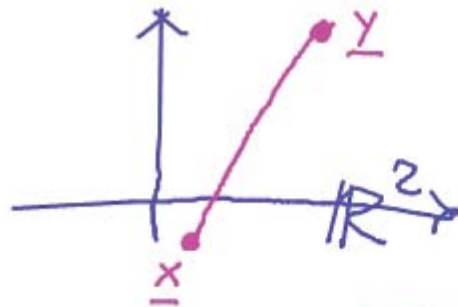

$$d_e(x, y) = \sqrt{(x_1 - y_1)^2 + (x_2 - y_2)^2}$$



$$2) d_p(x, y) = \left( \sum_{j=1}^k |x_j - y_j|^p \right)^{\frac{1}{p}}, \quad x = (x_1, \dots, x_k), y = (y_1, \dots, y_k) \in \mathbb{R}^k$$

$$3) \text{ discrete metric } d(x, y) = \begin{cases} 1 & x \neq y \\ 0 & x = y \end{cases}$$

Definition



$$N_r(x) = \{y \in X \mid d(x, y) < r\}$$

Example

1)  $\mathbb{R}, d(x,y) = |x-y|$

$N_r(x) = \{y \in \mathbb{R} \mid |x-y| < r\} = (x-r, x+r)$

$|y-x| < r$   
 $-r < y-x < r$

$x-r < y < x+r$



$(X, d)$  is the discrete metric &  $x_0 \in X$ .

2)  $N_2(x_0) = \{y \in X \mid d(x,y) < 2\} = X$ ,  $N_{\frac{1}{2}}(x_0) = \{y \in X \mid d(x,y) < \frac{1}{2}\}$

3)  $(\mathbb{R}^2, d_e)$

$N_1((0,0)) = \{(x,y) \in \mathbb{R}^2 \mid d_e((x,y), (0,0)) < 1\}$   
 $\sqrt{x^2 + y^2}$



the unit disk

$(\mathbb{R}^2, d_m)$

$N_1((0,0)) = \{(x,y) \in \mathbb{R}^2 \mid d_m((x,y), (0,0)) < 1\}$   
 $|x| + |y|$



$(\mathbb{R}^2, d_m)$

$N_1((0,0)) = \{(x,y) \in \mathbb{R}^2 \mid d_m((x,y), (0,0)) < 1\}$   
 $\max\{|x|, |y|\}$

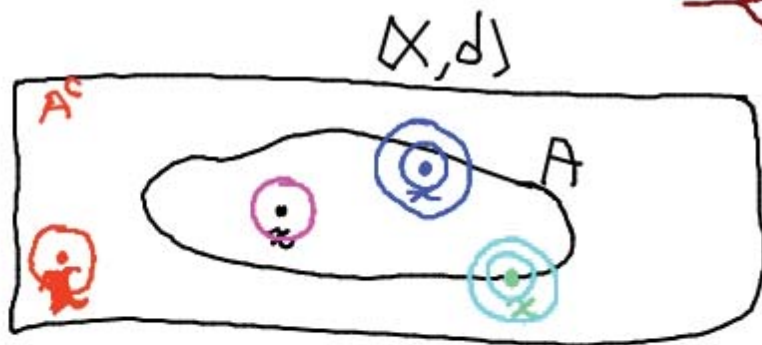
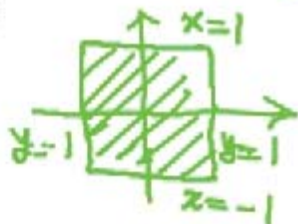

$x \in A^\circ \iff \exists r; N_r(x) \subseteq A$   
 $x$  is interior point of  $A$   
 $\equiv N_r(x) \cap A^c = \emptyset$

$x \in \text{Ext}(A) \iff \exists s; N_s(x) \cap A = \emptyset$   
 $x$  is exterior point  
 $\equiv N_s(x) \subseteq A^c$

$x \in \text{bd}(A) \iff \forall r; (N_r(x) \cap A \neq \emptyset \& N_r(x) \cap A^c \neq \emptyset)$   
 $x$  is boundary point

$x \in \bar{A} \iff \forall r; N_r(x) \cap A \neq \emptyset$   
 $x$  is a cluster point

$A$  is open  $\iff A = A^\circ$   
 $A$  is closed  $\iff A = \bar{A}$   
 $A$  is dense  $\iff \bar{A} = X$   
 $A$  is open  $\iff A^c$  is closed



In  $(\mathbb{R}^n, d_e)$ , a bounded and closed subset of  $\mathbb{R}^n$  is called compact.  $A = \bar{A}$

usual metric

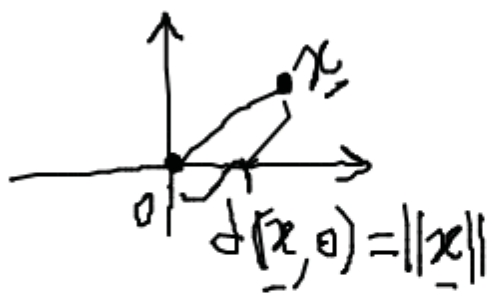

$\mathbb{R}^n$  is called compact.



A is called bounded if  $\exists x_0 \exists r; A \subset N(x_0, r)$

Th. If  $f: \mathbb{R}^n \rightarrow \mathbb{R}$  is a cts function on a compact set  $K \subset \mathbb{R}^n$ , then  $\exists p \in K \exists q \in K; f(p) = \max_{x \in K} f(x)$

$f(q) = \min_{x \in K} f(x)$

Counterexample:  $f: (0, \infty) \rightarrow \mathbb{R}$  is cts, but

$f(x) = \frac{1}{x}$

$\sup_{x \in (0, \infty)} f(x) = +\infty$

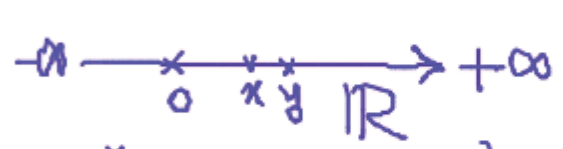
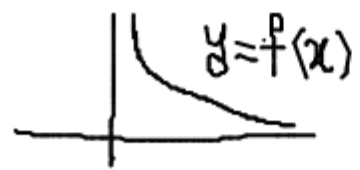

$\pm\infty$  are "not" real numbers.

$\mathbb{R}^* = \mathbb{R} \cup \{-\infty, +\infty\}$   
the extended real numbers

Every subset of  $\mathbb{R}$  is b.d. in  $\mathbb{R}^*$ .

$\forall x, -\infty < x < +\infty$

Arithmetic in  $\mathbb{R}^*$ :  $+\infty + (+\infty) = +\infty, a(+\infty) = \begin{cases} +\infty & a > 0 \\ -\infty & a < 0 \end{cases}$

$\lim_{x \rightarrow a} f(x) = l \in \mathbb{R}, \lim_{x \rightarrow a} g(x) = l' \in \mathbb{R} \Rightarrow \lim_{x \rightarrow a} (f(x) + g(x)) = l + l'$

$\lim_{x \rightarrow a} f(x) = +\infty, \lim_{x \rightarrow a} g(x) = l' \in \mathbb{R} \Rightarrow \lim_{x \rightarrow a} (f(x) + g(x)) = +\infty$

$\lim_{x \rightarrow a} f(x) = -\infty, \lim_{x \rightarrow a} g(x) = l' \in \mathbb{R} \Rightarrow \lim_{x \rightarrow a} (f(x) + g(x)) = -\infty$

$\lim_{x \rightarrow a} (f(x) + g(x)) = \lim_{x \rightarrow a} f(x) + \lim_{x \rightarrow a} g(x)$

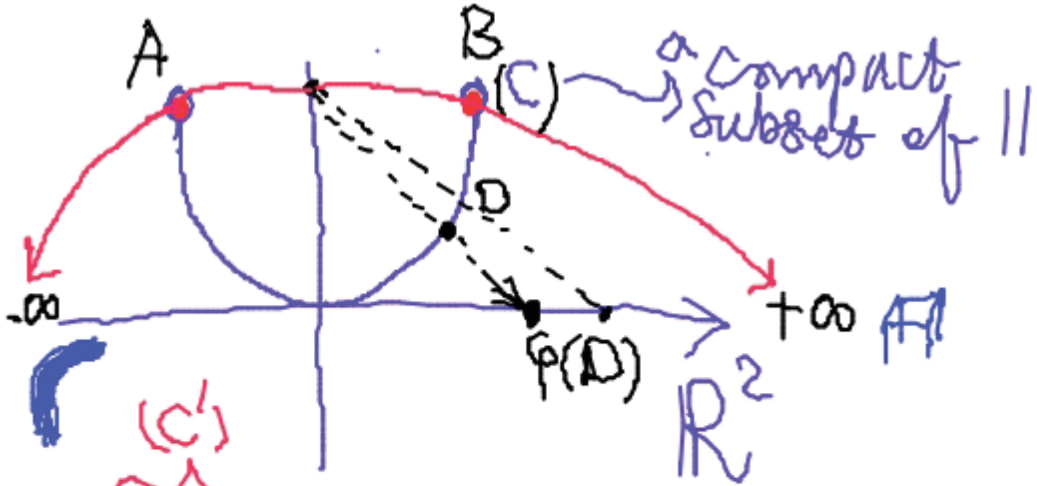

$$\begin{aligned} \varphi: (C) - \{A, B\} &\leftrightarrow \mathbb{R} \\ D &\mapsto \varphi(D) \end{aligned}$$

$$\begin{aligned} \tilde{\varphi}: (C) &\rightarrow \mathbb{R}^* = \mathbb{R} \cup \{\pm\infty\} \\ \text{Extension } \tilde{\varphi}(D) &= \begin{cases} \varphi(D) & D \in (C) \\ -\infty & D = A \\ +\infty & D = B \end{cases} \end{aligned}$$

If we define  $d(x^*, y^*) = d_e(\tilde{\varphi}^{-1}(x^*), \tilde{\varphi}^{-1}(y^*))$   
 then  $d^*$  is a new metric on  $\mathbb{R}^*$  and makes  $\mathbb{R}^*$   
 into a compact space.

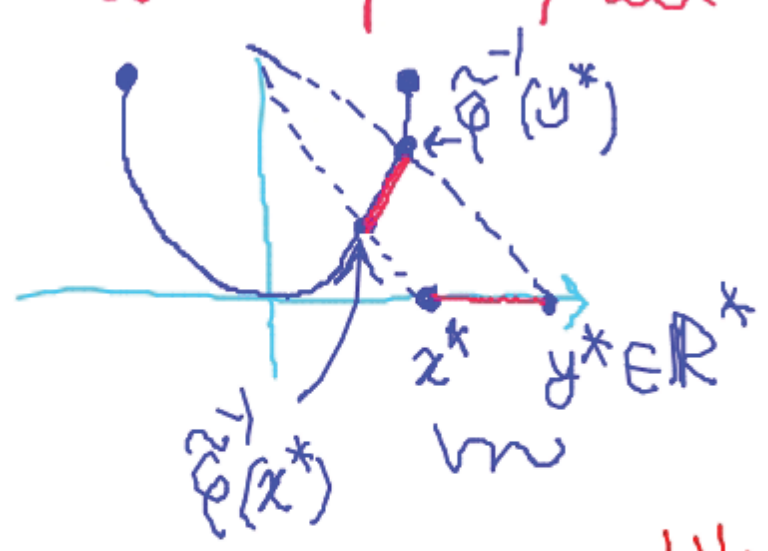

$$\psi: S - \{N\} \xrightarrow{1-1} \mathbb{C}$$

onto

$S$  a compact set  
 so is  $\mathbb{C} \cup \{\infty\}$

$$\tilde{\psi}: S \xrightarrow{1-1} \mathbb{C} \cup \{\infty\}$$

onto

not a  
 complex  
 number

$|z|=r \Rightarrow f(z)=\alpha z+\beta \Rightarrow w-\beta=\alpha z \Rightarrow |w-\beta|=|\alpha z| \Rightarrow |z|=r \Rightarrow |w-\beta|=r|\alpha|$  the image of  $|z|=r$  is the circle  $|w-\beta|=r|\alpha|$

**Theorem 7.3 Circle-Preserving Property**

If  $C$  is a circle in the  $z$ -plane and if  $T$  is a linear fractional transformation given by (3), then the image of  $C$  under  $T$  is either a circle or a line in the extended  $w$ -plane. The image is a line if and only if  $c \neq 0$  and the pole  $z = -d/c$  is on the circle  $C$ .

$$T(z) = \begin{cases} \frac{az+b}{cz+d}, & z \neq -\frac{d}{c}, z \neq \infty \\ \infty, & z = -\frac{d}{c} \\ \frac{a}{c}, & z = \infty. \end{cases} \quad (3)$$

**Proof** When  $c = 0$ ,  $T$  is a linear function, and we saw in Section 2.3 that linear functions map circles onto circles. It remains to be seen that the theorem still holds for  $c \neq 0$ . Assume then that  $c \neq 0$ . From (2) we have that  $T(z) = f \circ g \circ h(z)$ , where  $f(z) = Az + B$  and  $h(z) = cz + d$  are linear functions and  $g(z) = 1/z$  is the reciprocal function. Observe that since  $h$  is a linear mapping, the image  $C'$  of the circle  $C$  under  $h$  is a circle. We now examine two cases:

$$T(z) = \frac{az+b}{cz+d} = \frac{a}{c}z + \frac{b}{c}$$



**Case 1** Assume that the origin  $w = 0$  is on the circle  $C'$ . This occurs if and only if the pole  $z = -d/c$  is on the circle  $C$ . From the Remarks in Section 2.5, if  $w = 0$  is on  $C'$ , then the image of  $C'$  under  $g(z) = 1/z$  is either a horizontal or vertical line  $L$ . Furthermore, because  $f$  is a linear function, the image of the line  $L$  under  $f$  is also a line. Thus, we have shown that if the pole  $z = -d/c$  is on the circle  $C$ , then the image of  $C$  under  $T$  is a line.

$$(f \circ g \circ h)(z) = (f \circ g)(h(z)) = f\left(g\left(\frac{1}{cz+d}\right)\right) = f\left(\frac{1}{cz+d}\right) = \frac{az+b}{cz+d} = \frac{bc-ad}{c} \frac{1}{cz+d} + \frac{a}{c}$$

**Case 2** Assume that the point  $w = 0$  is not on  $C'$ . That is, the pole  $z = -d/c$  is not on the circle  $C$ . Let  $C'$  be the circle given by  $|w - w_0| = \rho$ . If we set  $\xi = f(w) = 1/w$  and  $\xi_0 = f(w_0) = 1/w_0$ , then for any point  $w$  on  $C'$  we have

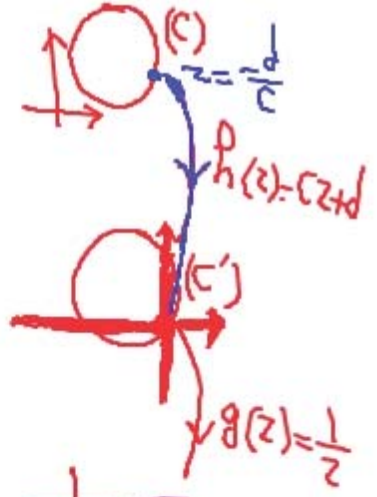

$$|\xi - \xi_0| = \left| \frac{1}{w} - \frac{1}{w_0} \right| = \frac{|w - w_0|}{|w| |w_0|} = \rho |\xi_0| |\xi|. \quad (4)$$

It can be shown that the set of points satisfying the equation

$$|\xi - a| = \lambda |\xi - b| \quad (5)$$

is a line if  $\lambda = 1$  and is a circle if  $\lambda > 0$  and  $\lambda \neq 1$ . See Problem 28 in Exercises 7.2. Thus, with the identifications  $a = \xi_0$ ,  $b = 0$ , and  $\lambda = \rho |\xi_0|$  we see that (4) can be put into the form (5). Since  $w = 0$  is not on  $C'$ , we have  $|w_0| \neq \rho$ , or, equivalently,  $\lambda = \rho |\xi_0| \neq 1$ . This implies that the set of points given by (4) is a circle. Finally, since  $f$  is a linear function, the image of this circle under  $f$  is again a circle, and so we conclude that the image of  $C$  under  $T$  is a circle.

### EXAMPLE 2 Image of a Circle

Find the image of the unit circle  $|z| = 1$  under the linear fractional transformation  $T(z) = (z + 2)/(z - 1)$ . What is the image of the interior  $|z| < 1$  of this circle?

**Solution** The pole of  $T$  is  $z = 1$  and this point is on the unit circle  $|z| = 1$ . Thus, from Theorem 7.3 we conclude that the image of the unit circle is a line. Since the image is a line, it is determined by any two points. Because  $T(-1) = -\frac{1}{2}$  and  $T(i) = -\frac{1}{2} - \frac{3}{2}i$ , we see that the image is the line  $u = -\frac{1}{2}$ . To answer the second question we first note that a linear fractional transformation is a rational function, and so it is continuous on its domain. As a consequence, the image of the interior  $|z| < 1$  of the unit circle is either the half-plane  $u < -\frac{1}{2}$  or the half-plane  $u > -\frac{1}{2}$ . Using  $z = 0$  as a test point, we find that  $T(0) = -2$ , which is to the left of the line  $u = -\frac{1}{2}$ , and so the image is the half-plane  $u < -\frac{1}{2}$ . This mapping is illustrated in Figure 7.13. The circle  $|z| = 1$  is shown in color in Figure 7.13(a) and its image  $u = -\frac{1}{2}$  is shown in black in Figure 7.13(b).

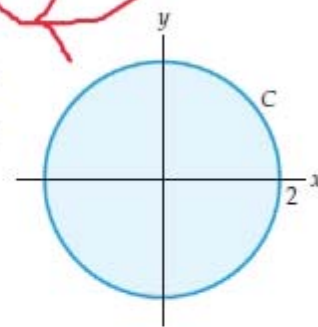
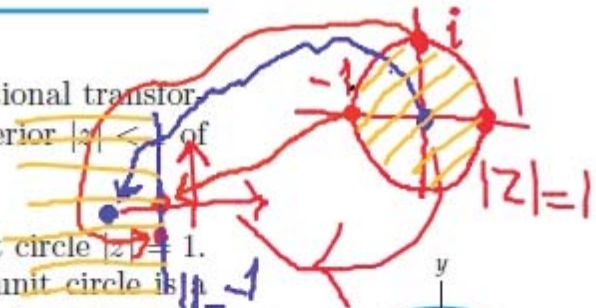

(a) The circle  $|z| = 1$

$$w = \frac{z+2}{z-1}$$

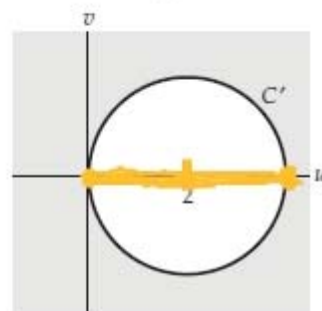

(b) The image of the circle in (a)

### EXAMPLE 3 Image of a Circle

Find the image of the circle  $|z| = 2$  under the linear fractional transformation  $T(z) = (z + 2)/(z - 1)$ . What is the image of the disk  $|z| \leq 2$  under  $T$ ?

**Solution** In this example the pole  $z = 1$  does not lie on the circle  $|z| = 2$ , and so Theorem 7.3 indicates that the image of  $|z| = 2$  is a circle  $C'$ . To find an algebraic description of  $C'$ , we first note that the circle  $|z| = 2$  is symmetric with respect to the  $x$ -axis. That is, if  $z$  is on the circle  $|z| = 2$ , then so is  $\bar{z}$ . Furthermore, we observe that for all  $z$ ,

$$T(\bar{z}) = \frac{\bar{z} + 2}{\bar{z} - 1} = \frac{\overline{z + 2}}{\overline{z - 1}} = \overline{\left(\frac{z + 2}{z - 1}\right)} = \overline{T(z)}.$$

Hence, if  $z$  and  $\bar{z}$  are on the circle  $|z| = 2$ , then we must have that both  $w = T(z)$  and  $\bar{w} = \overline{T(z)} = T(\bar{z})$  are on the circle  $C'$ . It follows that  $C'$

is symmetric with respect to the  $u$ -axis. Since  $z = 2$  and  $-2$  are on the circle  $|z| = 2$ , the two points  $T(2) = 4$  and  $T(-2) = 0$  are on  $C'$ . The symmetry of  $C'$  implies that 0 and 4 are endpoints of a diameter, and so  $C'$  is the circle  $|w - 2| = 2$ . Using  $z = 0$  as a test point, we find that  $w = T(0) = -2$ , which is outside the circle  $|w - 2| = 2$ . Therefore, the image of the interior of the circle  $|z| = 2$  is the exterior of the circle  $|w - 2| = 2$ . In summary, the disk  $|z| \leq 2$  shown in color in Figure 7.14(a) is mapped onto the region  $|w - 2| \geq 2$  shown in gray in Figure 7.14(b) by the linear fractional transformation  $T(z) = (z + 2)/(z - 1)$ .

Figure 7.14 The linear fractional transformation  $T(z) = (z + 2)/(z - 1)$

## Linear Fractional Transformations as Matrices

Matrices

can be used to simplify many of the computations associated with linear fractional transformations. In order to do so, we associate the matrix

$$\mathbf{A} = \begin{pmatrix} a & b \\ c & d \end{pmatrix} \quad (6)$$

with the linear fractional transformation

$$T(z) = \frac{az + b}{cz + d} \quad (7)$$

The assignment in (6) is not unique because if  $e$  is a nonzero complex number, then the linear fractional transformation  $T(z) = (az + b)/(cz + d)$  is also given by  $T(z) = (eaz + eb)/(ecz + ed)$ . However, if  $e \neq 1$ , then the two matrices

$$\mathbf{A} = \begin{pmatrix} a & b \\ c & d \end{pmatrix} \quad \text{and} \quad \mathbf{B} = \begin{pmatrix} ea & eb \\ ec & ed \end{pmatrix} = e\mathbf{A} \quad (8)$$

are not equal even though they represent the same linear fractional transformation.

It is easy to verify that the composition  $T_2 \circ T_1$  of two linear fractional transformations

$$T_1(z) = (a_1z + b_1)/(c_1z + d_1) \quad \text{and} \quad T_2(z) = (a_2z + b_2)/(c_2z + d_2)$$

is represented by the product of matrices

$$\begin{pmatrix} a_2 & b_2 \\ c_2 & d_2 \end{pmatrix} \begin{pmatrix} a_1 & b_1 \\ c_1 & d_1 \end{pmatrix} = \begin{pmatrix} a_2a_1 + b_2c_1 & a_2b_1 + b_2d_1 \\ c_2a_1 + d_2c_1 & c_2b_1 + d_2d_1 \end{pmatrix}. \quad (9)$$

In Problem 27 of Exercises 7.2 you are asked to find the formula for  $T^{-1}(z)$  by solving the equation  $w = T(z)$  for  $z$ . The formula for the inverse function  $T^{-1}(z)$  of a linear fractional transformation  $T$  of (7) is represented by the inverse of the matrix  $\mathbf{A}$  in (6)

$$\mathbf{A}^{-1} = \begin{pmatrix} a & b \\ c & d \end{pmatrix}^{-1} = \frac{1}{ad - bc} \begin{pmatrix} d & -b \\ -c & a \end{pmatrix}.$$

By identifying  $e = \frac{1}{ad - bc}$  in (8) we can also represent  $T^{-1}(z)$  by the matrix

$$\begin{pmatrix} d & -b \\ -c & a \end{pmatrix}. \quad (10)$$

$$\begin{aligned} [T_2 \circ T_1](z) &= T_2\left(\frac{a_1z + b_1}{c_1z + d_1}\right) \\ &= \frac{a_2\left(\frac{a_1z + b_1}{c_1z + d_1}\right) + b_2}{c_2\left(\frac{a_1z + b_1}{c_1z + d_1}\right) + d_2} \\ &= \frac{a_2(a_1z + b_1) + b_2(c_1z + d_1)}{c_2(a_1z + b_1) + d_2(c_1z + d_1)} \\ &= \frac{a_2a_1z + a_2b_1 + b_2c_1z + b_2d_1}{c_2a_1z + c_2b_1 + d_2c_1z + d_2d_1} \\ &= \frac{(a_2a_1 + b_2c_1)z + (a_2b_1 + b_2d_1)}{(c_2a_1 + d_2c_1)z + (c_2b_1 + d_2d_1)} \end{aligned}$$

### Definition 7.3 Cross-Ratio

The cross-ratio of the complex numbers  $z$ ,  $z_1$ ,  $z_2$ , and  $z_3$  is the complex number

$$\frac{z - z_1}{z - z_3} \frac{z_2 - z_3}{z_2 - z_1}. \quad (11)$$

When computing a cross-ratio, we must be careful with the order of the complex numbers. For example, you should verify that the cross-ratio of 0, 1,  $i$ , and 2 is  $\frac{3}{4} + \frac{1}{4}i$ , whereas the cross-ratio of 0,  $i$ , 1, and 2 is  $\frac{1}{4} - \frac{1}{4}i$ .

We extend the concept of the cross-ratio to include points in the extended complex plane by using the limit formula (24) from the Remarks in Section 2.6. For example, the cross-ratio of, say,  $\infty$ ,  $z_1$ ,  $z_2$ , and  $z_3$  is given by the limit

### Theorem 7.4 Cross-Ratios and Linear Fractional Transformations

If  $w = T(z)$  is a linear fractional transformation that maps the distinct points  $z_1$ ,  $z_2$ , and  $z_3$  onto the distinct points  $w_1$ ,  $w_2$ , and  $w_3$ , respectively, then

$$\frac{z - z_1}{z - z_3} \frac{z_2 - z_3}{z_2 - z_1} = \frac{w - w_1}{w - w_3} \frac{w_2 - w_3}{w_2 - w_1} \quad (12)$$

for all  $z$ .

**Proof** Let  $R$  be the linear fractional transformation

$$R(z) = \frac{z - z_1}{z - z_3} \frac{z_2 - z_3}{z_2 - z_1}, \quad (13)$$

and note that  $R(z_1) = 0$ ,  $R(z_2) = 1$ , and  $R(z_3) = \infty$ . Consider also the linear fractional transformation

$$S(w) = \frac{w - w_1}{w - w_3} \frac{w_2 - w_3}{w_2 - w_1}. \quad (14)$$

For the transformation  $S$ , we have  $S(w_1) = 0$ ,  $S(w_2) = 1$ , and  $S(w_3) = \infty$ . Therefore, the points  $z_1$ ,  $z_2$ , and  $z_3$  are mapped onto the points  $w_1$ ,  $w_2$ , and  $w_3$ , respectively, by the linear fractional transformation  $S^{-1}(R(z))$ . From this it follows that 0, 1, and  $\infty$  are mapped onto 0, 1, and  $\infty$ , respectively, by the composition  $T^{-1}(S^{-1}(R(z)))$ . Now it is a straightforward exercise to verify that the only linear fractional transformation that maps 0, 1, and  $\infty$  onto 0, 1, and  $\infty$  is the identity mapping. See Problem 30 in Exercises 7.2. From this we conclude that  $T^{-1}(S^{-1}(R(z))) = z$ , or, equivalently, that  $R(z) = S(T(z))$ . Identifying  $w = T(z)$ , we have shown that  $R(z) = S(w)$ . Therefore, from (13) and (14) we have

$$\frac{z - z_1}{z - z_3} \frac{z_2 - z_3}{z_2 - z_1} = \frac{w - w_1}{w - w_3} \frac{w_2 - w_3}{w_2 - w_1}.$$

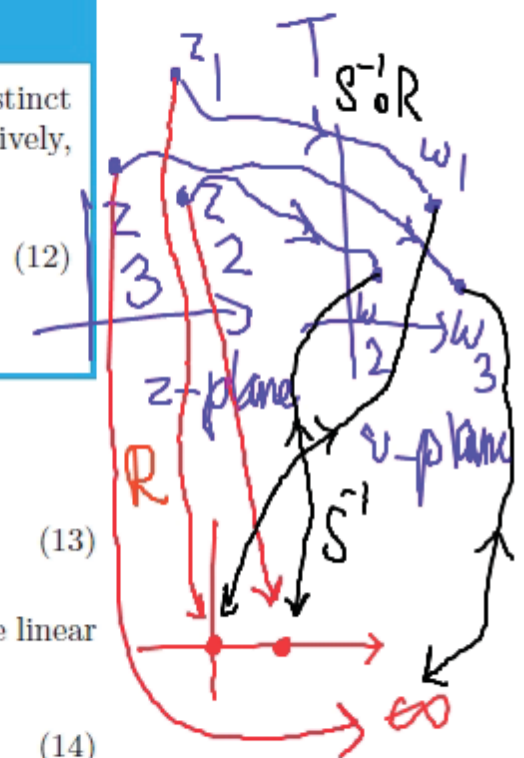

**EXAMPLE 5** Constructing a Linear Fractional Transformation

Construct a linear fractional transformation that maps the points  $1$ ,  $i$ , and  $-1$  on the unit circle  $|z| = 1$  onto the points  $-1$ ,  $0$ ,  $1$  on the real axis. Determine the image of the interior  $|z| < 1$  under this transformation.

**Solution** Identifying  $z_1 = 1$ ,  $z_2 = i$ ,  $z_3 = -1$ ,  $w_1 = -1$ ,  $w_2 = 0$ , and  $w_3 = 1$ , in (12) we see from Theorem 7.4 that the desired mapping  $w = T(z)$  must satisfy

$$\frac{z - 1}{z - (-1)} \frac{i - (-1)}{i - 1} = \frac{w - (-1)}{w - 1} \frac{0 - 1}{0 - (-1)}.$$

After solving for  $w$  and simplifying we obtain

$$w = T(z) = \frac{z - i}{iz - 1}.$$

Using the test point  $z = 0$ , we obtain  $T(0) = i$ . Therefore, the image of the interior  $|z| < 1$  is the upper half-plane  $v > 0$ .

**EXAMPLE 6** Constructing a Linear Fractional Transformation

Construct a linear fractional transformation that maps the points  $-i$ ,  $1$ , and  $\infty$  on the line  $y = x - 1$  onto the points  $1$ ,  $i$ , and  $-1$  on the unit circle  $|w| = 1$ .

**Solution** We proceed as in Example 5. Using (24) of Section 2.6, we find that the cross-ratio of  $z$ ,  $z_1 = -i$ ,  $z_2 = 1$ , and  $z_3 = \infty$  is

$$\lim_{z_3 \rightarrow \infty} \frac{z + i}{z - z_3} \frac{1 - z_3}{1 + i} = \lim_{z_3 \rightarrow 0} \frac{z + i}{z - 1/z_3} \frac{1 - 1/z_3}{1 + i} = \lim_{z_3 \rightarrow 0} \frac{z + i}{z z_3 - 1} \frac{z_3 - 1}{1 + i} = \frac{z + i}{1 + i}.$$

Now from (12) of Theorem 7.4 with  $w_1 = 1$ ,  $w_2 = i$ , and  $w_3 = -1$ , the desired mapping  $w = T(z)$  must satisfy

$$\frac{z + i}{1 + i} = \frac{w - 1}{w + 1} \frac{i + 1}{i - 1}.$$

After solving for  $w$  and simplifying we obtain

$$w = T(z) = \frac{z + 1}{-z + 1 - 2i}.$$